

Hackney

Global Expedition Vehicle Project

BEV – Basecamp Expedition Vehicle

- Chassis Components
- Design Illustrations
- Key Dimensions
- System Schematics

Hackney BEV Chassis Components

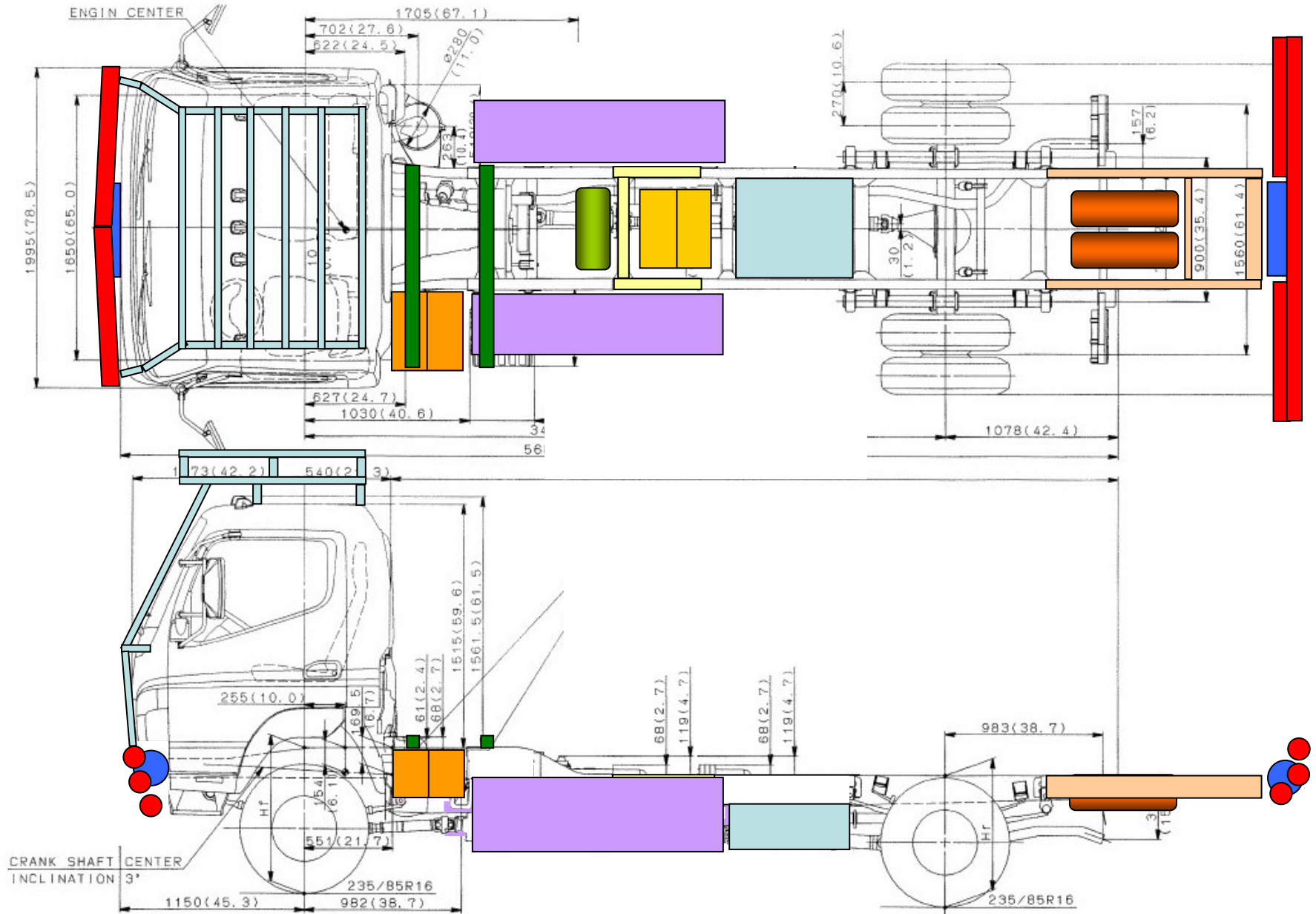

Hackney BEV Chassis Components

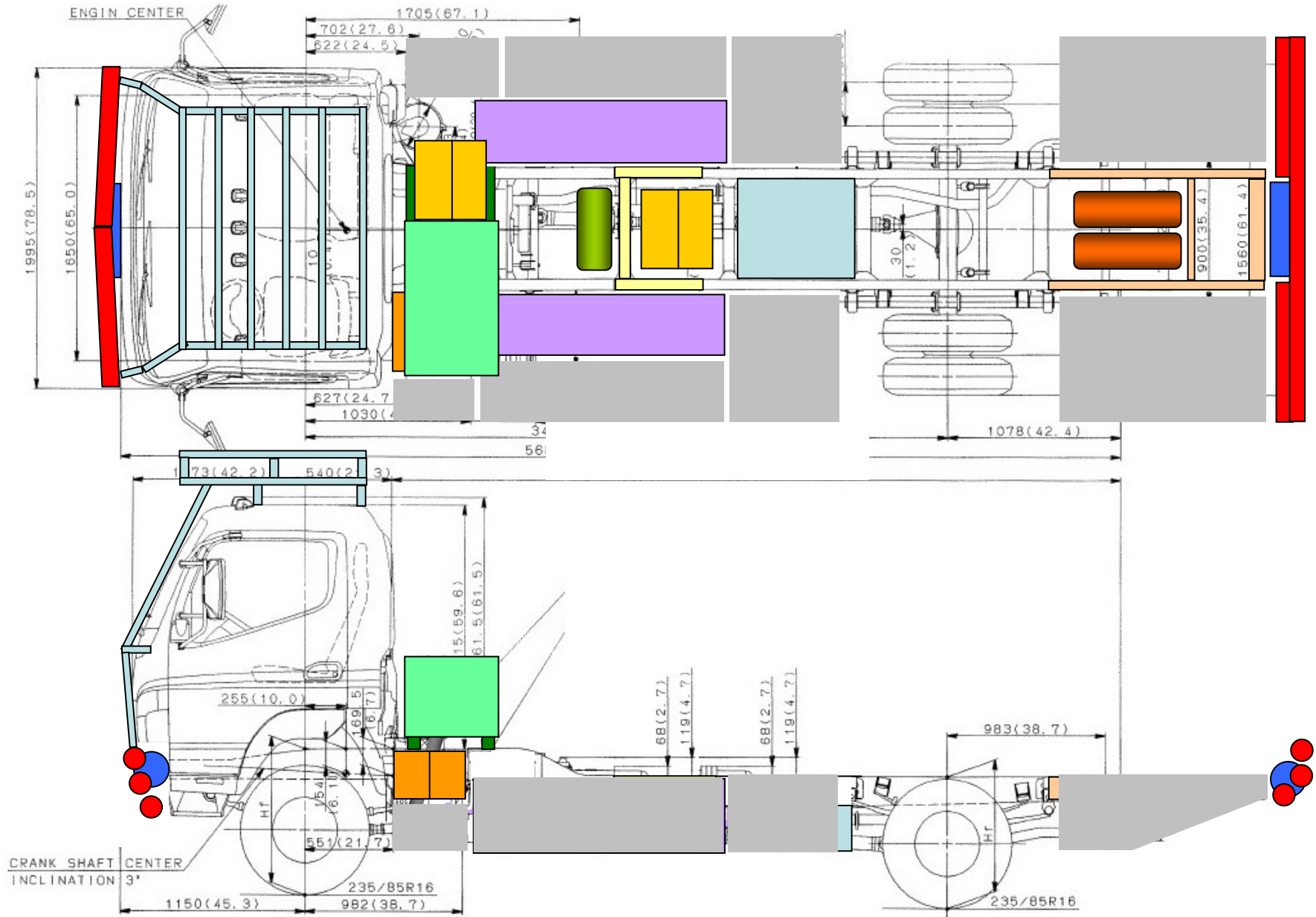

Hackney BEV Chassis Components

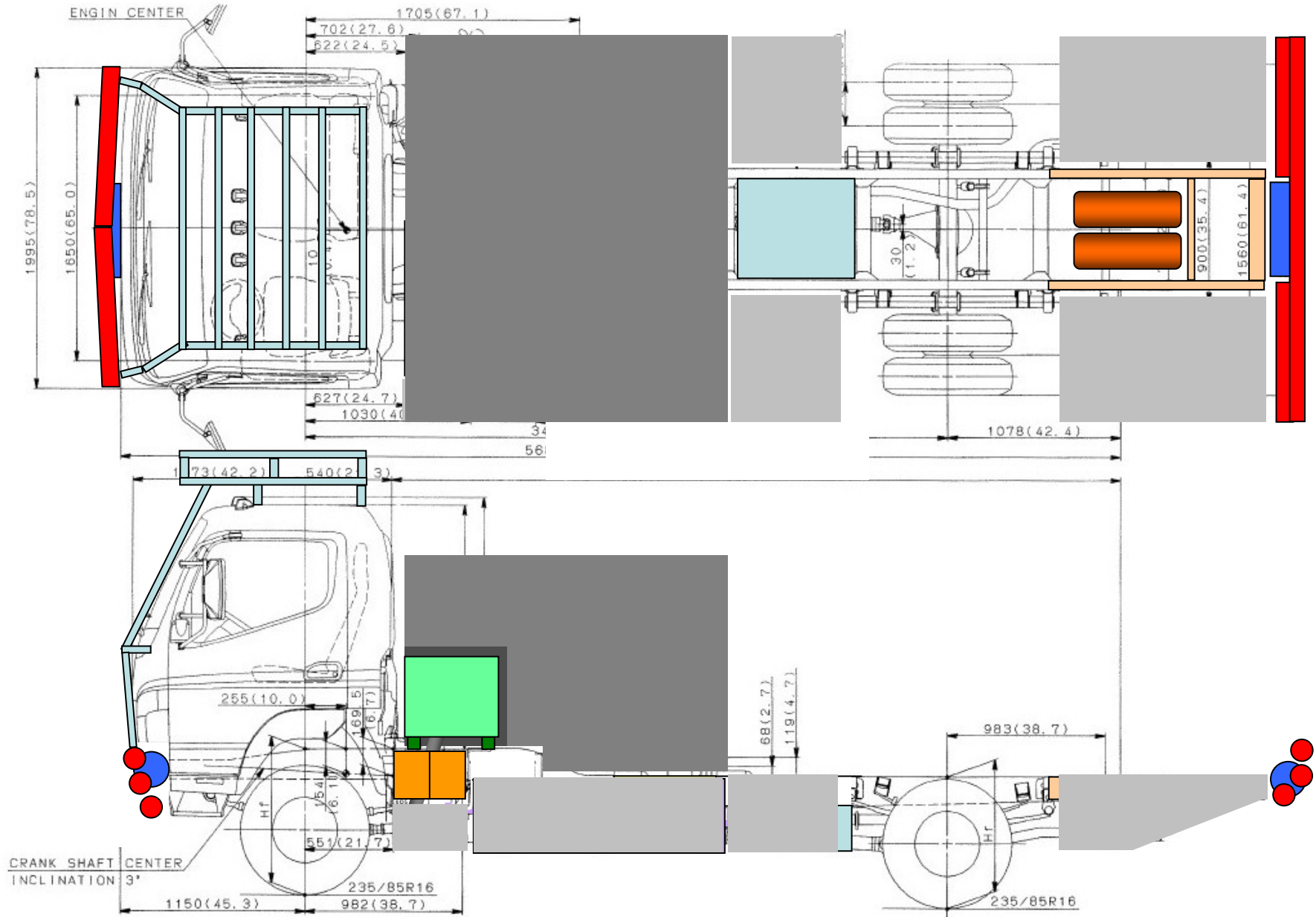

Hackney BEV Chassis Components

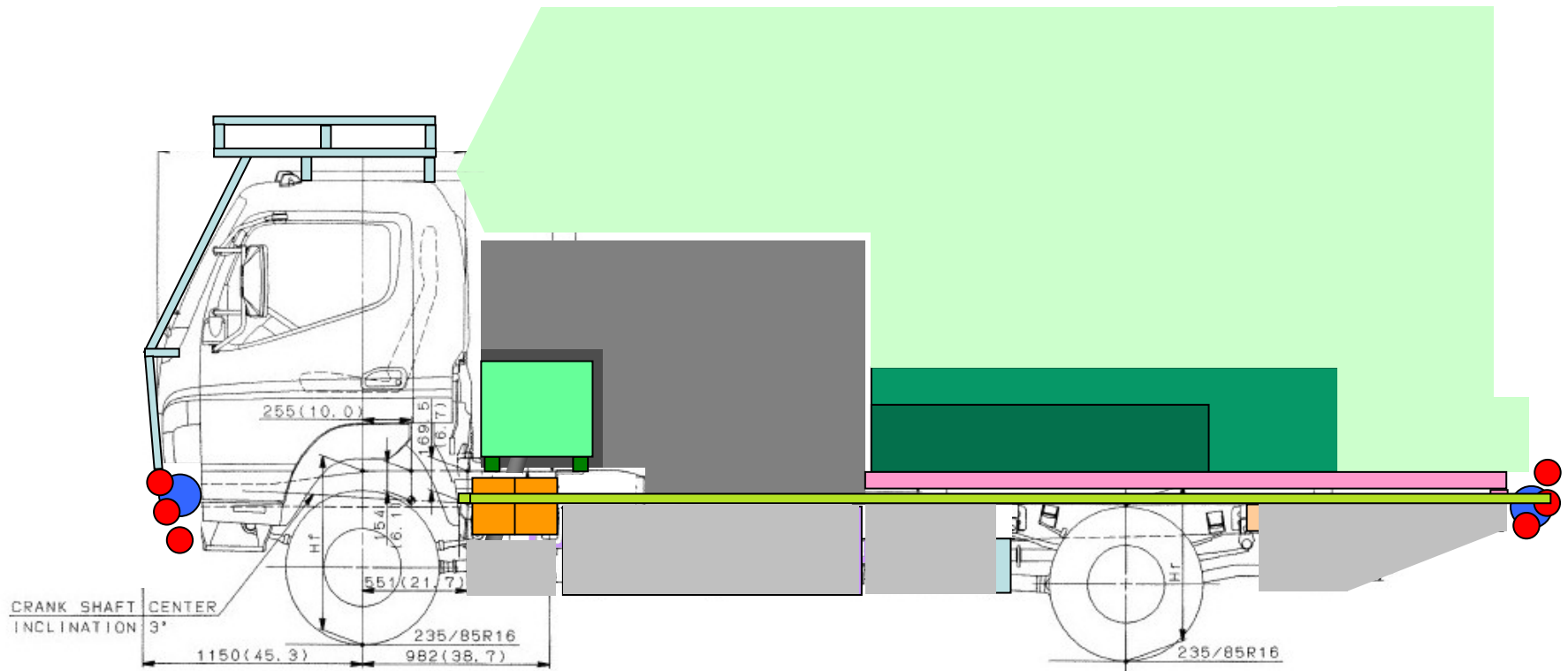

Hackney BEV Chassis Components

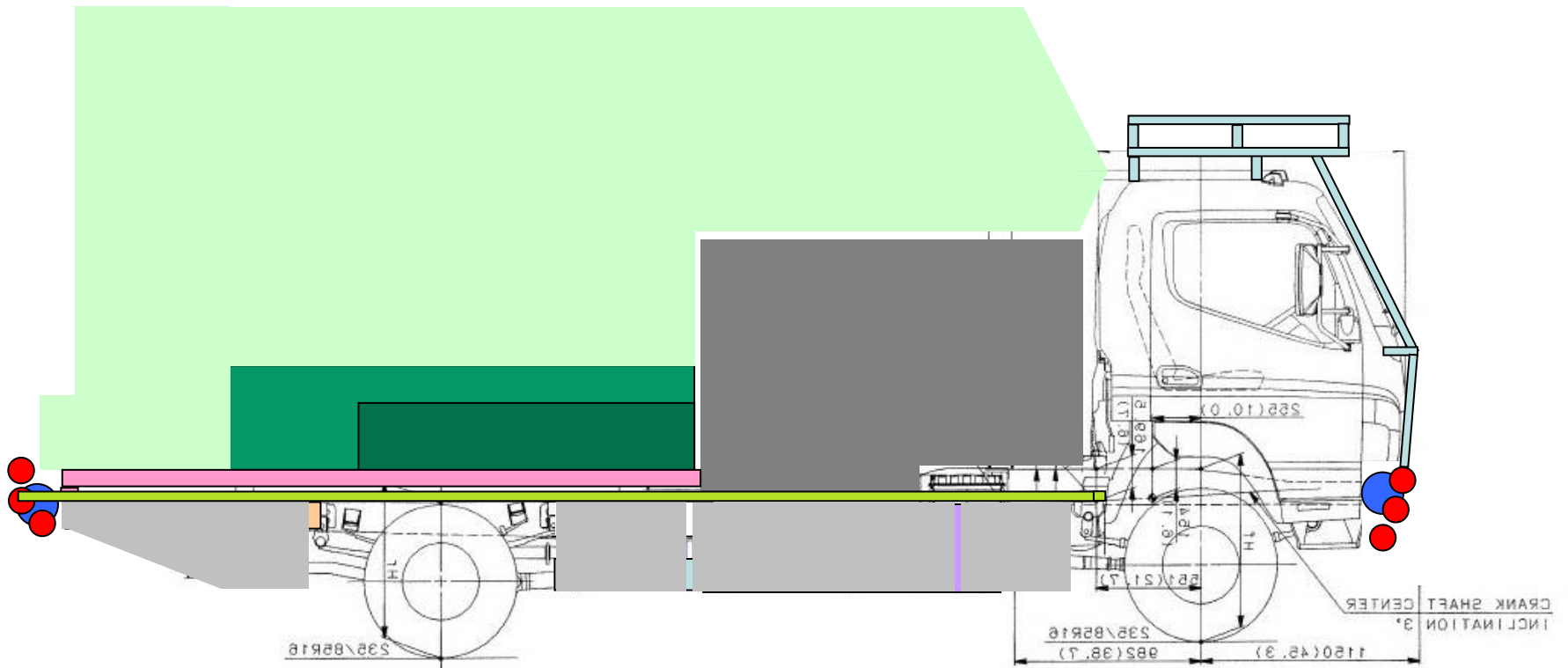

Hackney BEV Chassis Components

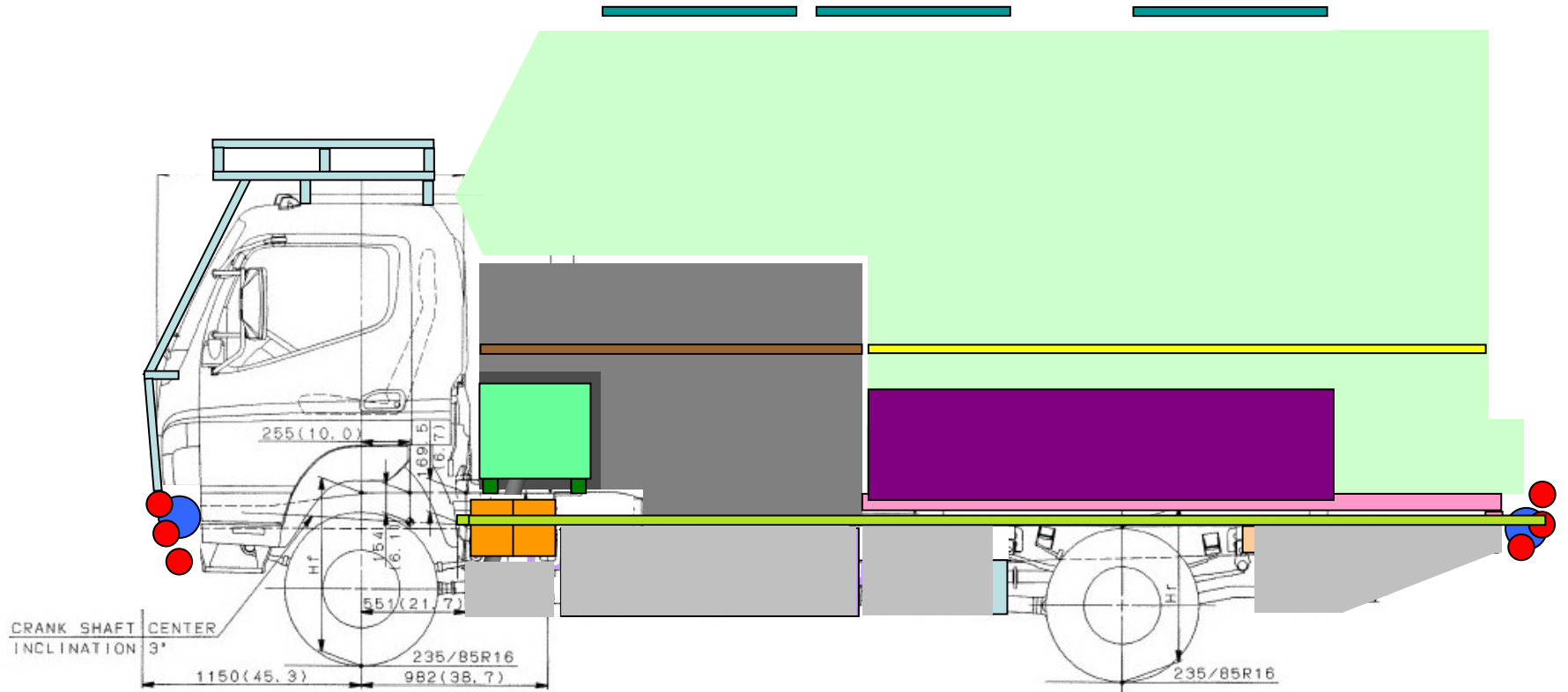

Hackney BEV Chassis Components

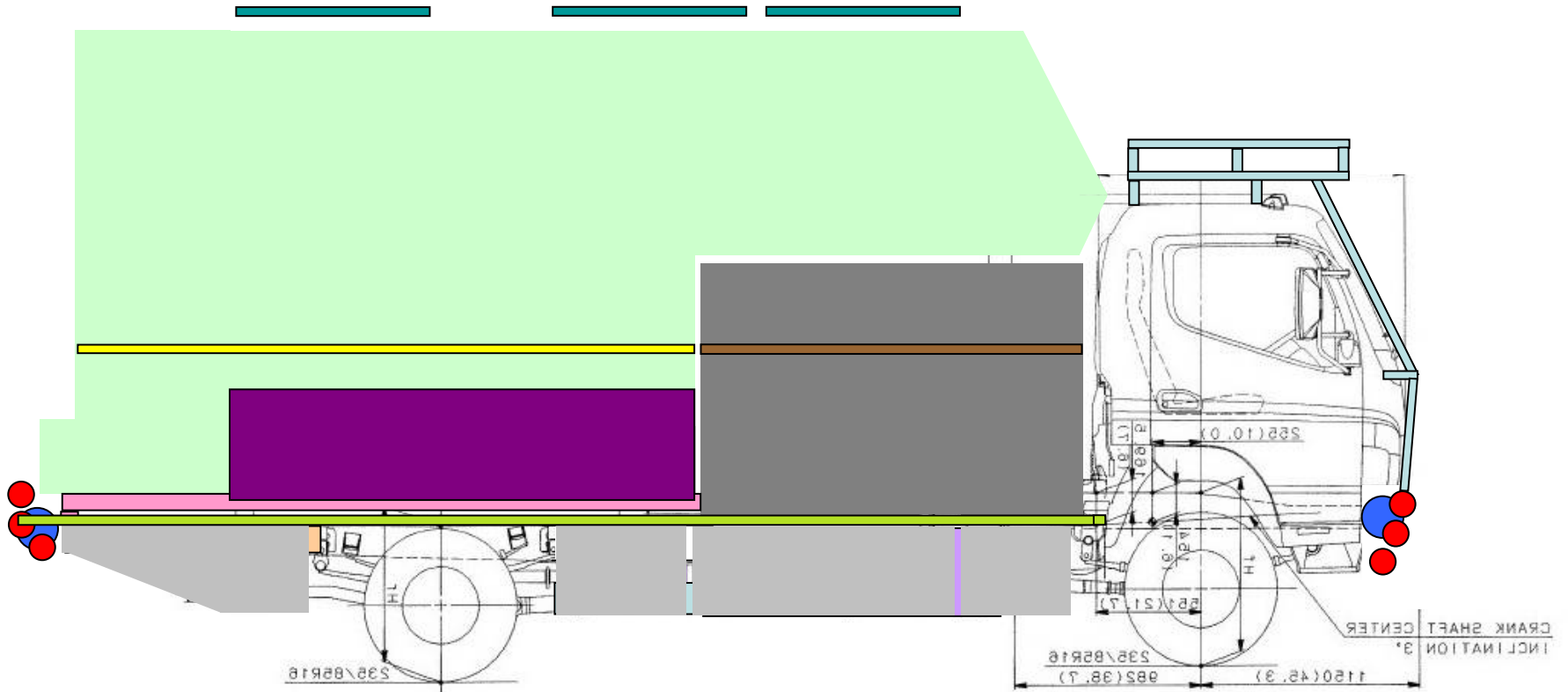

Hackney BEV Chassis Components

Key Dimensions

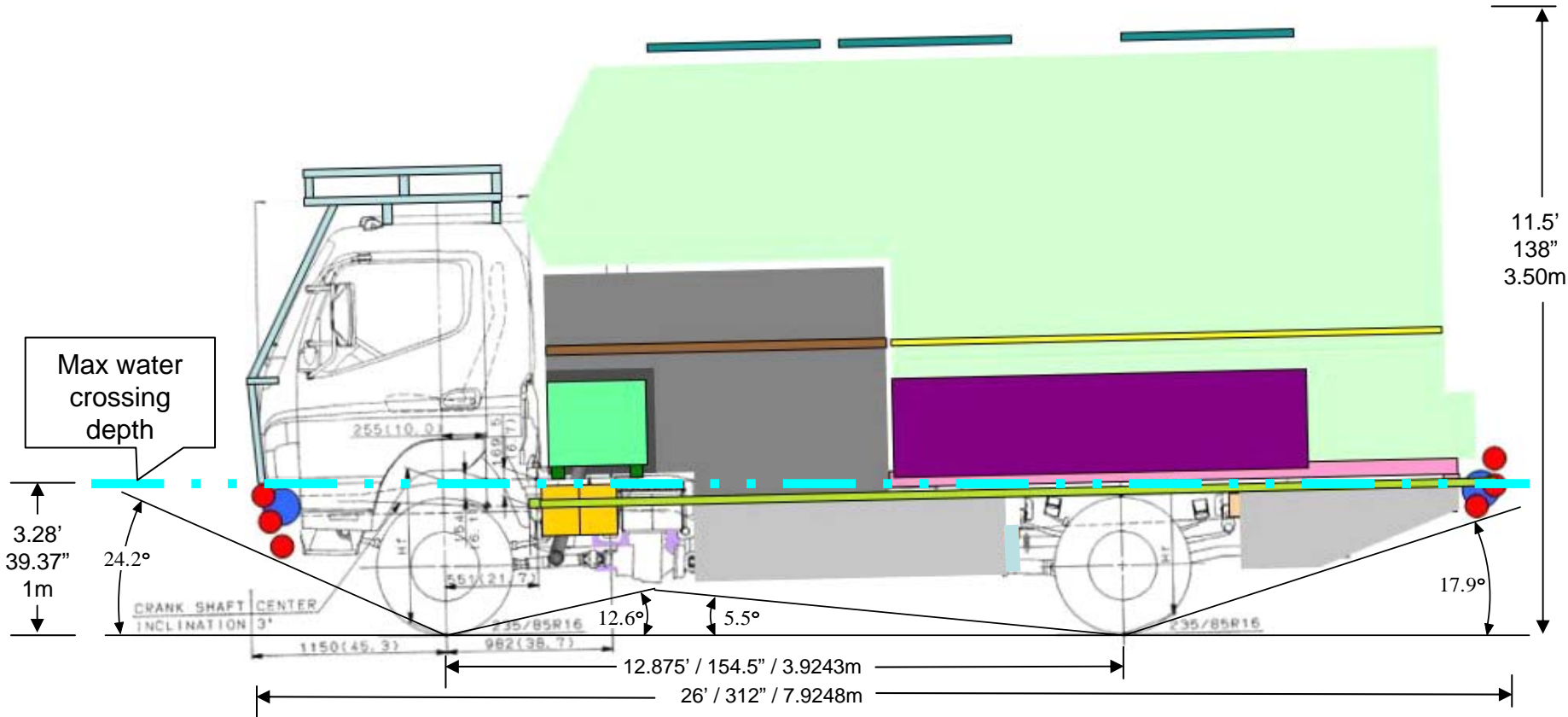

Hackney BEV Chassis Components

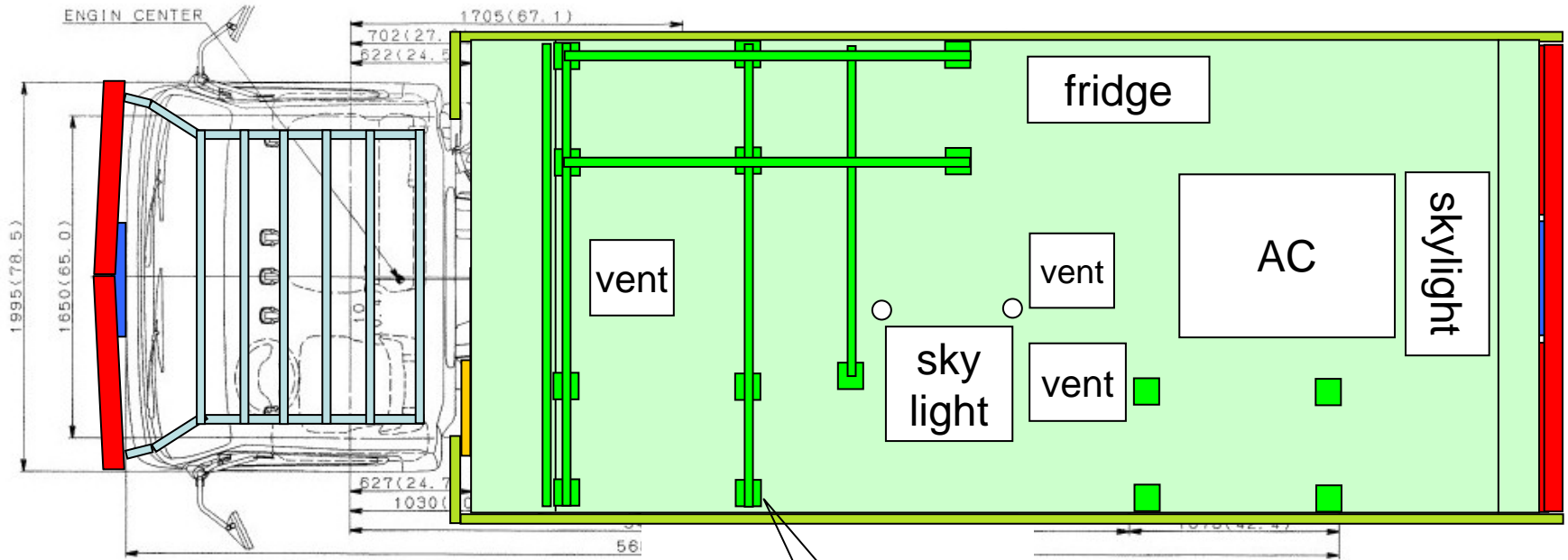

Guard rail on sacrificial bracket – height of top of AC & vents

Solar panel mounting frame

Guard rail on sacrificial bracket – height of top of AC & vents



Hackney BEV Chassis Components

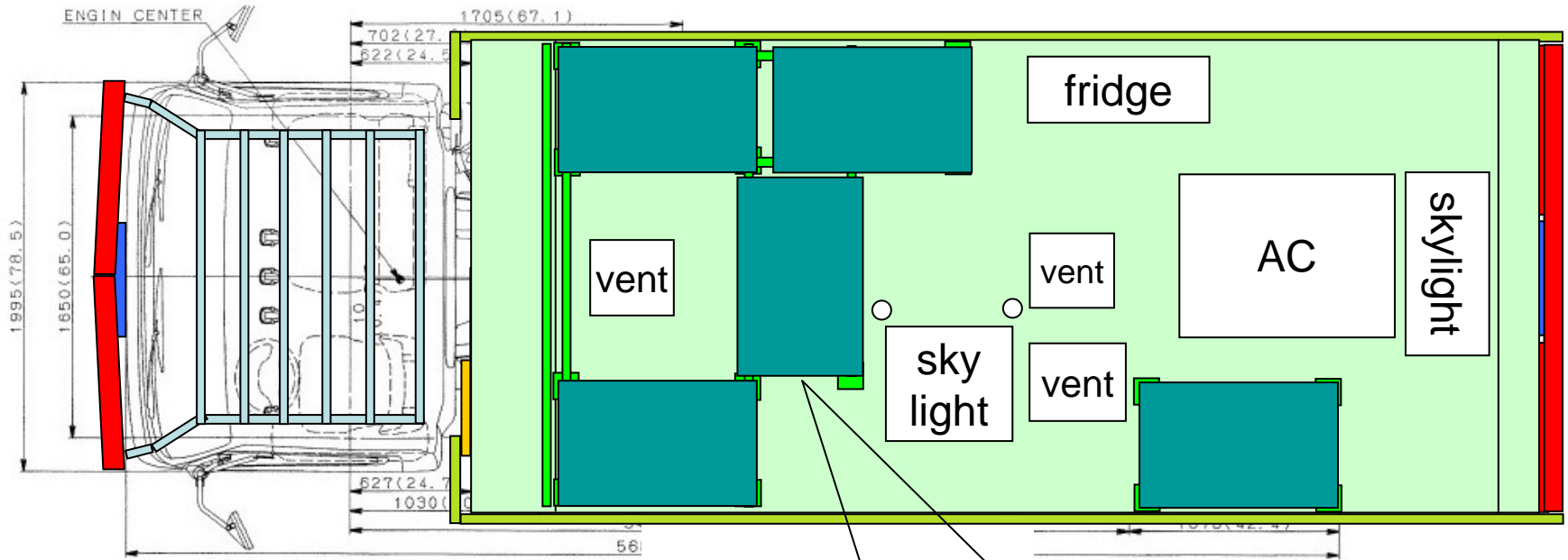

Guard rail on sacrificial bracket – height of top of AC & vents

Kyocera KC85T solar panels
25.7in/65.28cm x 39.6in/100.59cm
24 pounds / 10.89 kilos

Guard rail on sacrificial bracket – height of top of AC & vents



Minimum
1in/2.54cm
air gap

Hackney BEV Chassis Components

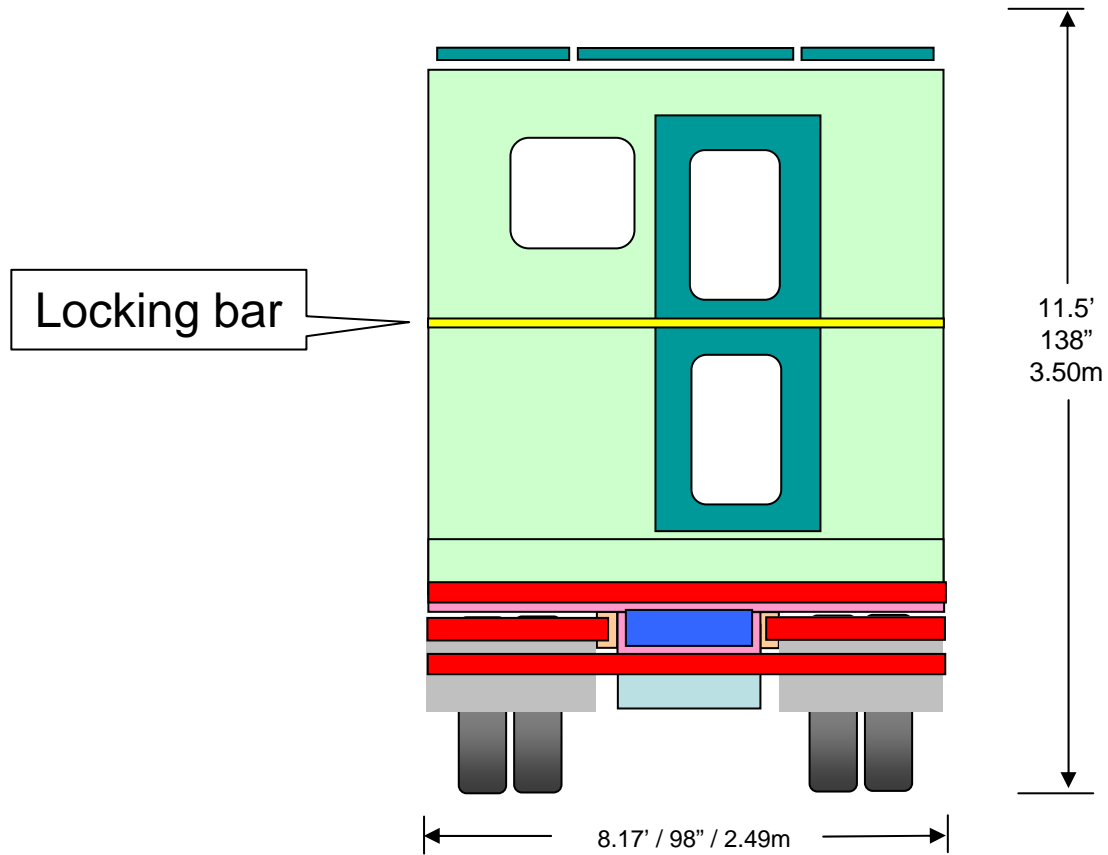

Hackney BEV Chassis Components

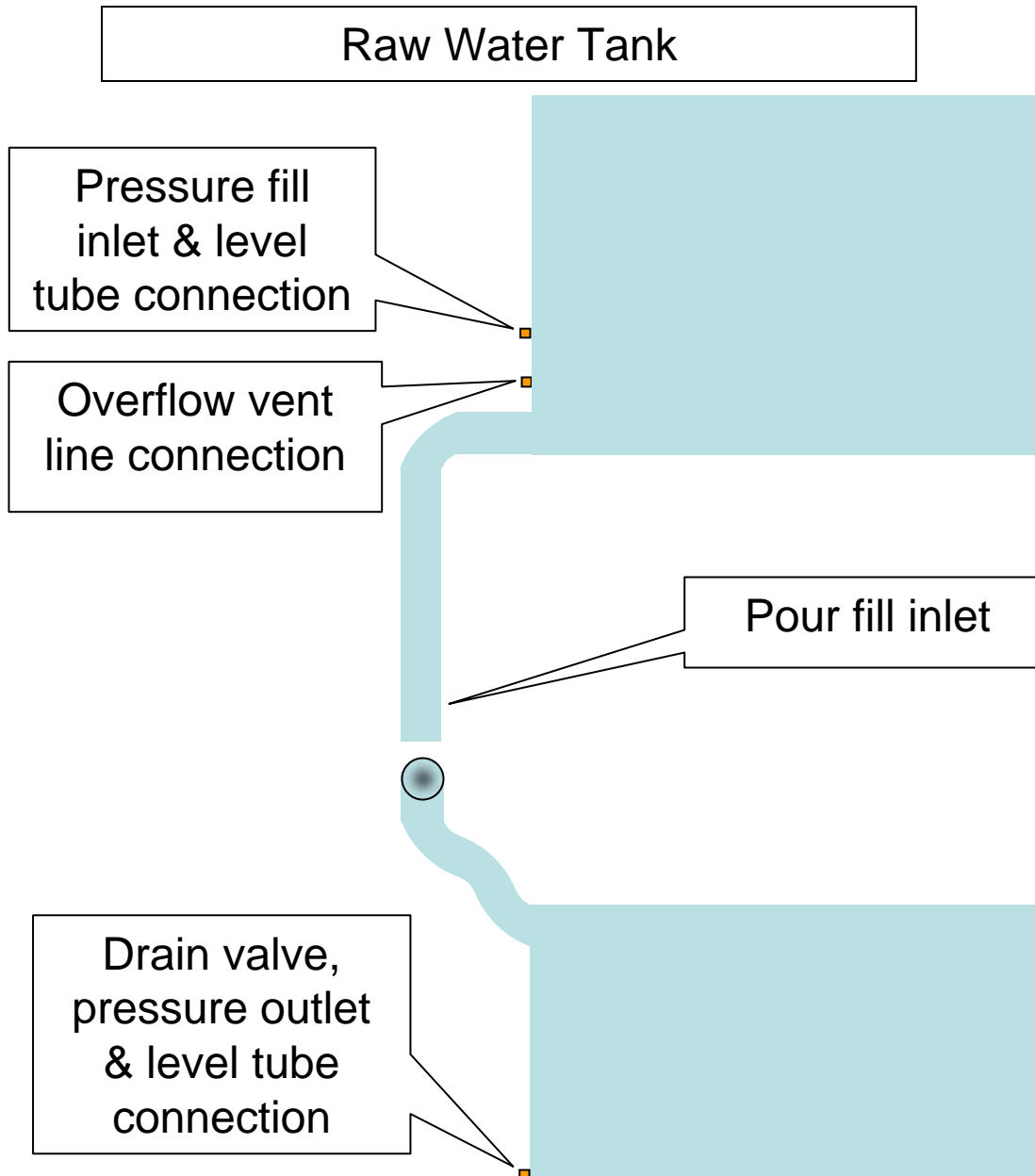

Hackney BEV Chassis Components

Driver's Side Lower Rear Storage Box

Macerator pump switch
mounted on front lip of box

LP Remote fill panel



1. Raw sewage inlet hose opening on inboard side of storage box
2. 12VDC feed required for macerator pump

Hackney BEV Chassis Components

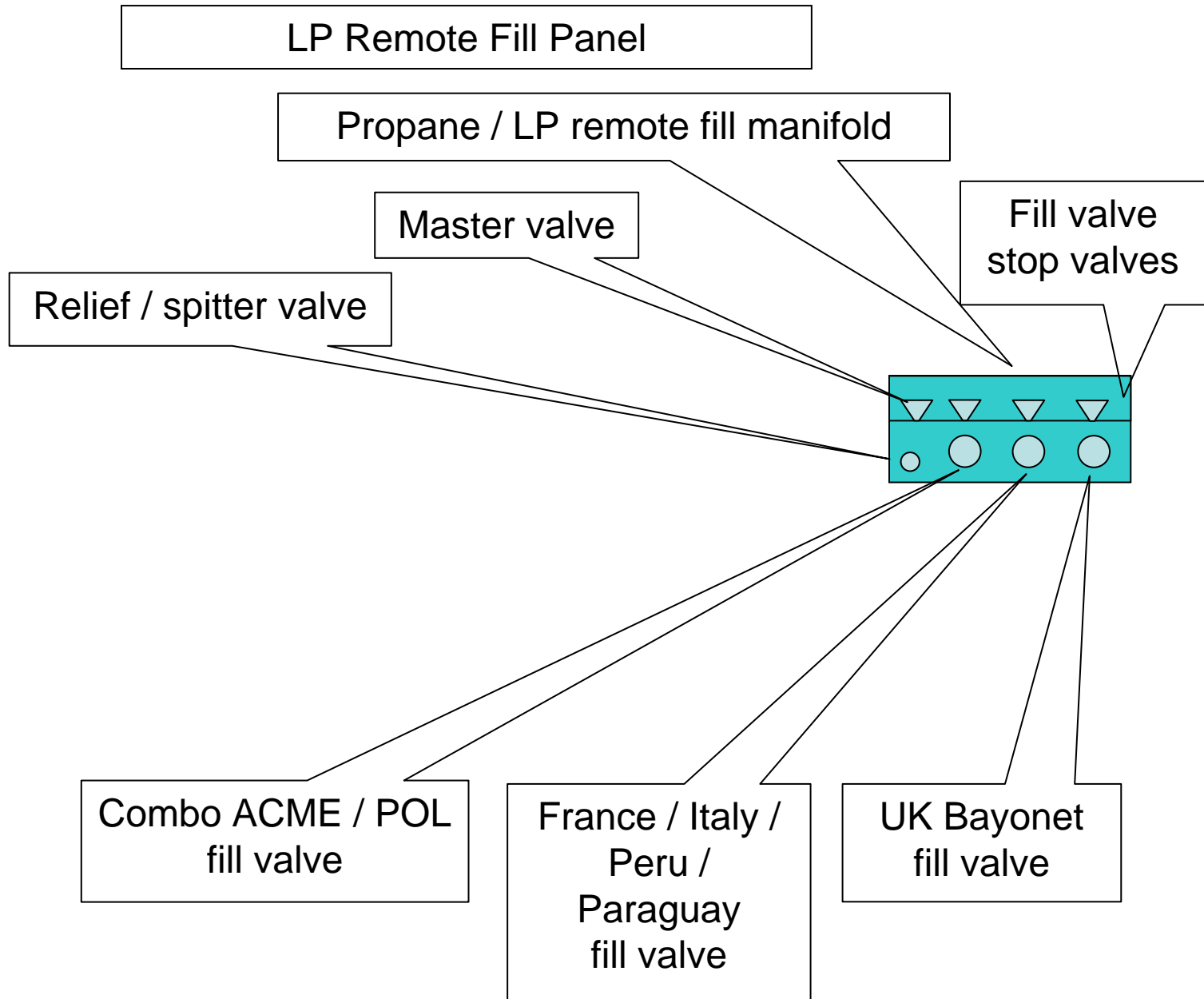

Hackney BEV Chassis Components

Driver's Side Lower Storage Box

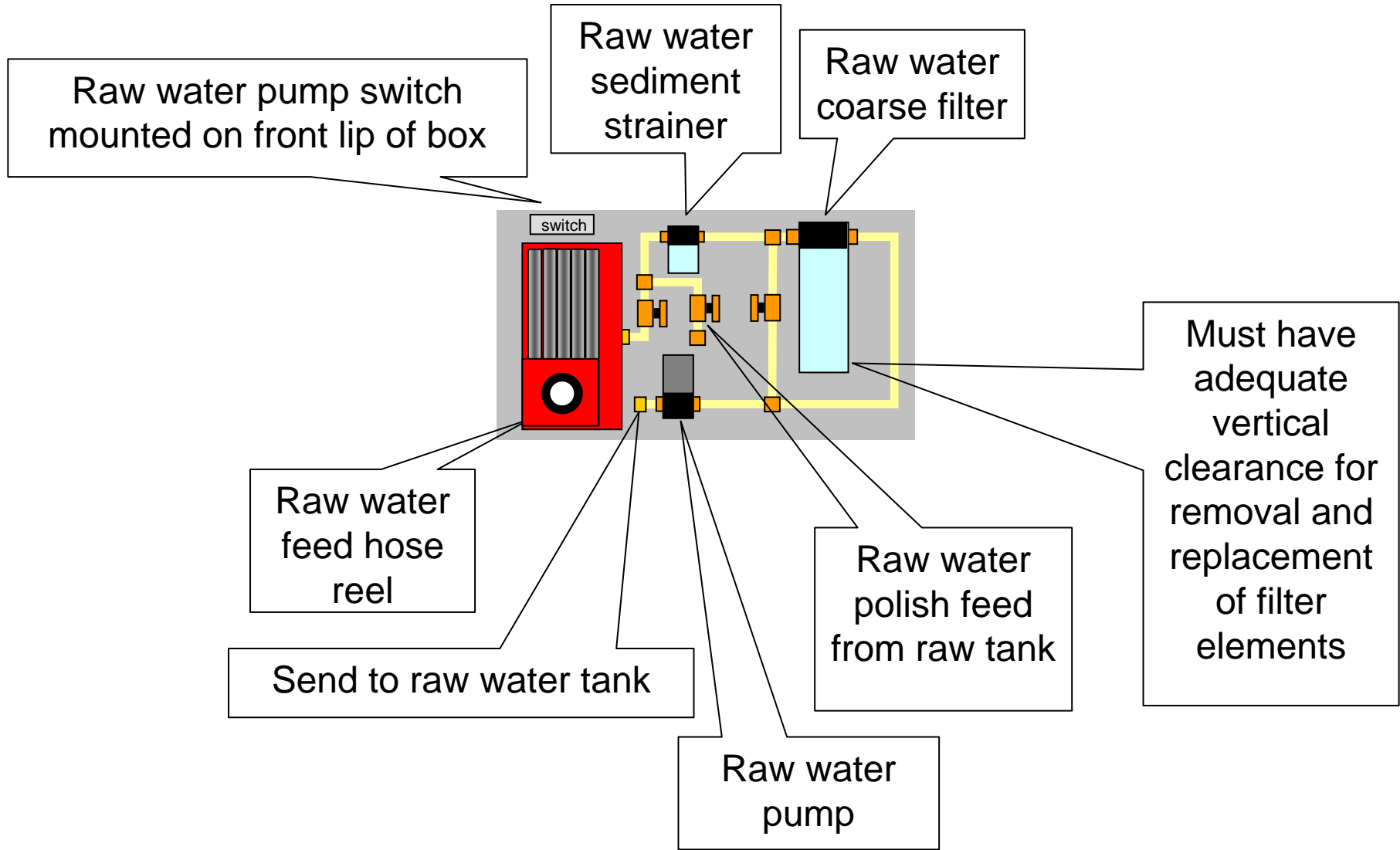

Hackney BEV Chassis Components

Driver's Side Garage

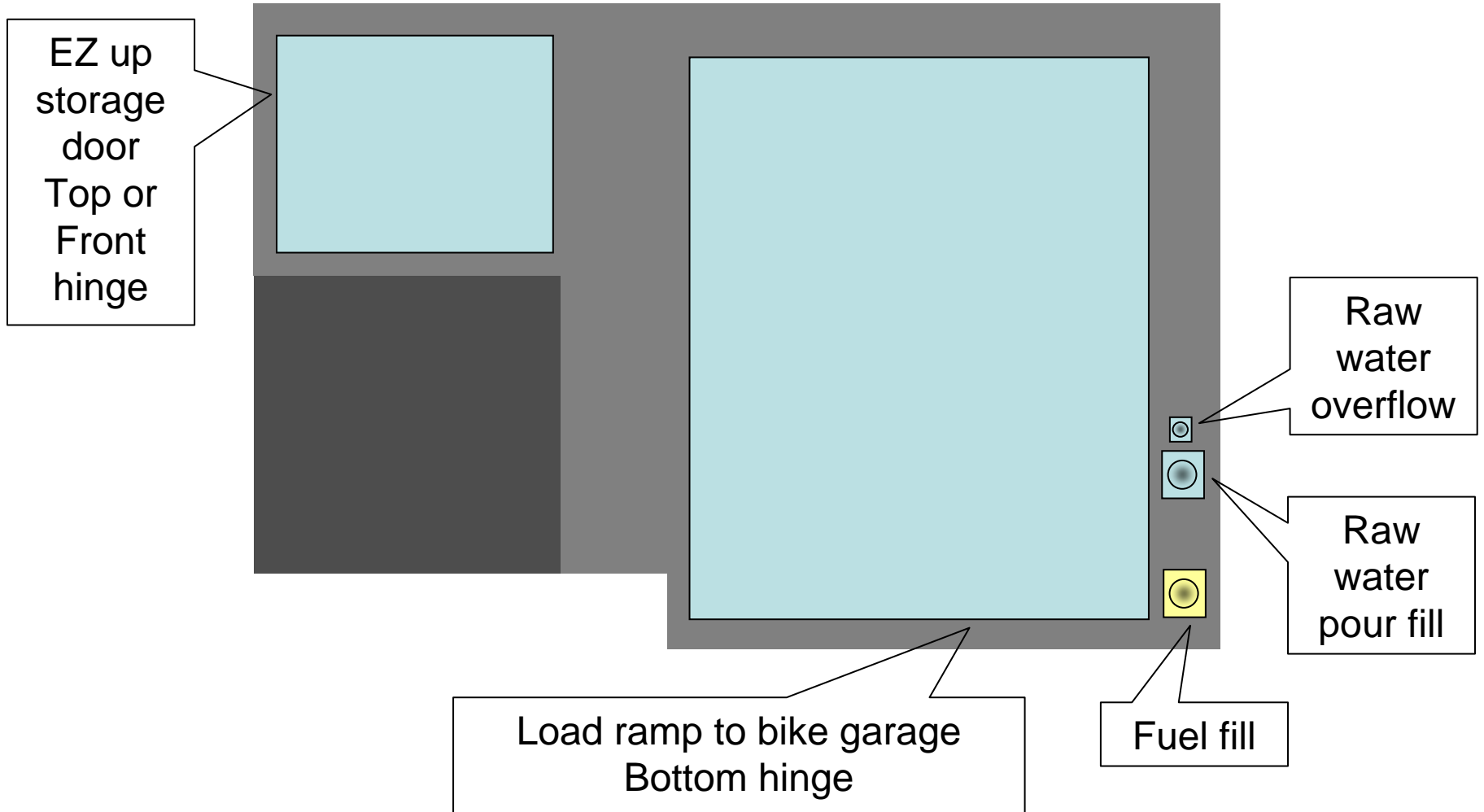

Hackney BEV Chassis Components

Curb Side Garage

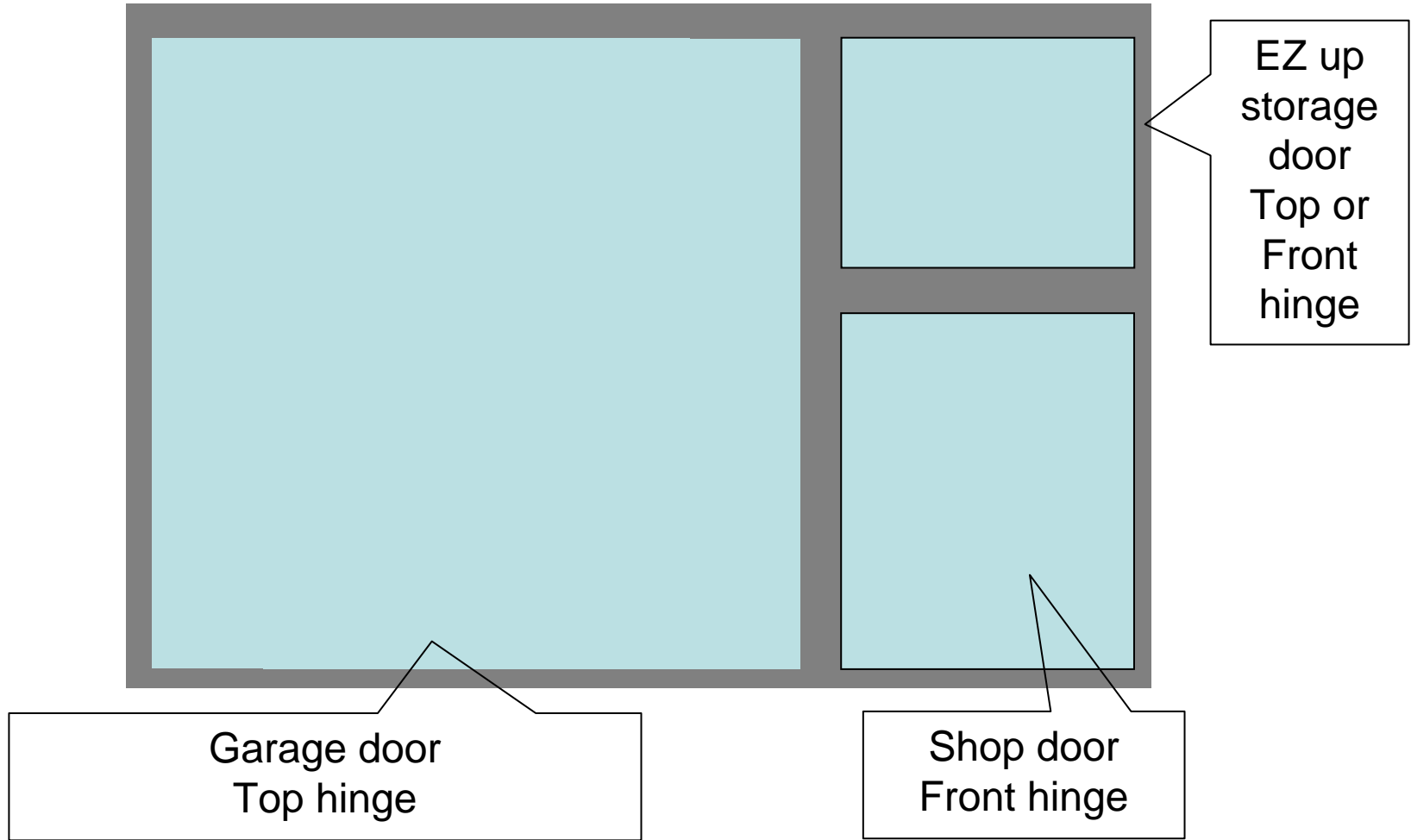

Hackney BEV Chassis Components

Curb Side Lower Rear Storage Box

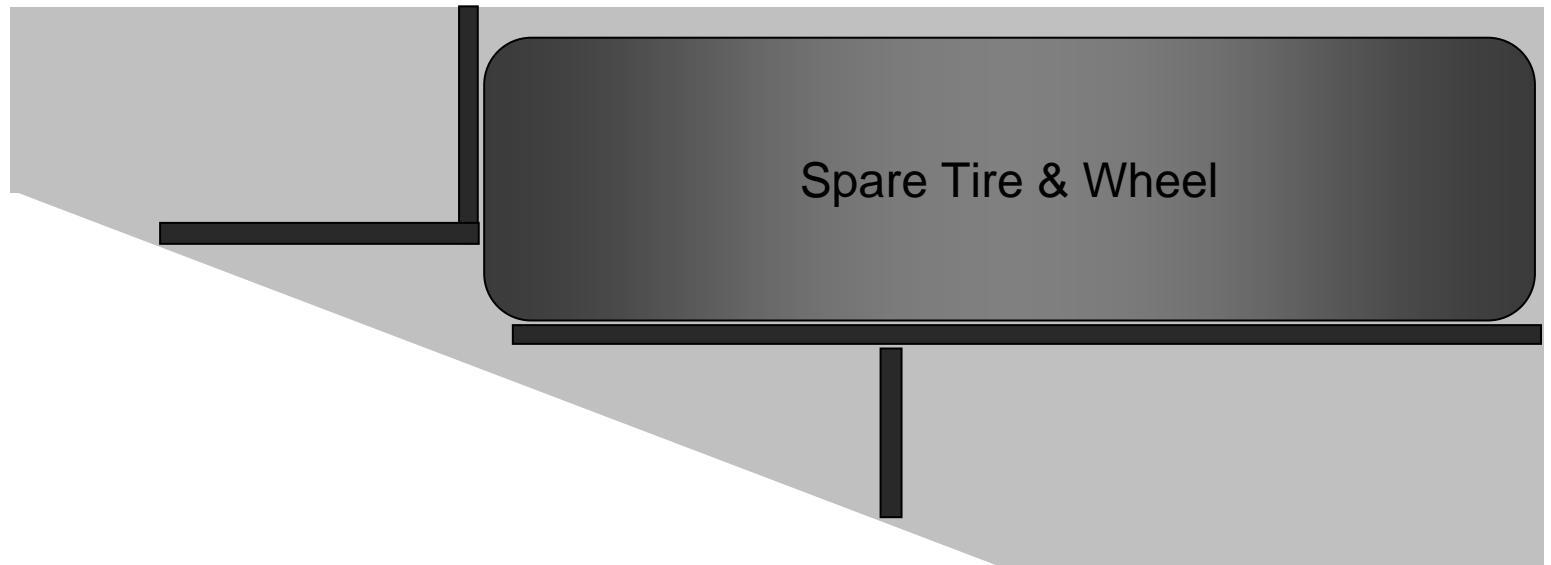

Hackney BEV Chassis Components

LP Grill Compartment

Rear curb side compartment of
Bigfoot 30C10.11 camper

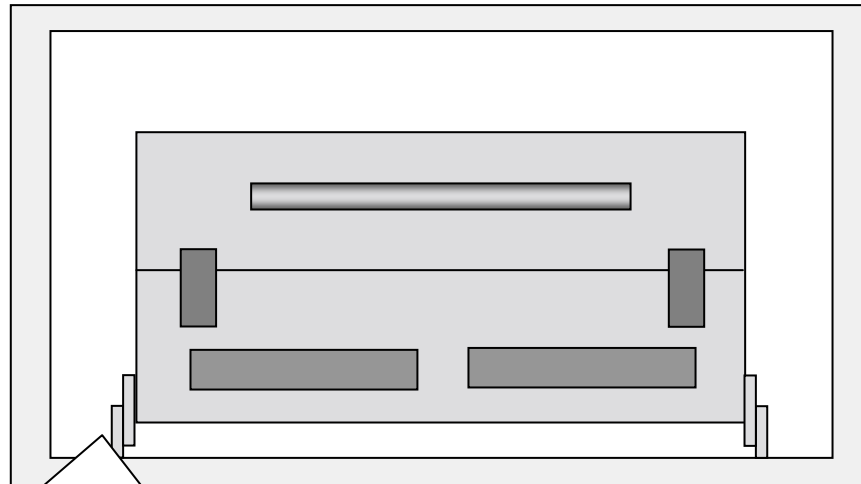

Jackson Grills
Stainless Steel Versa 100
Mounted on Kwikool slides

Hackney BEV Chassis Components

Driver's Side Upper Storage Box

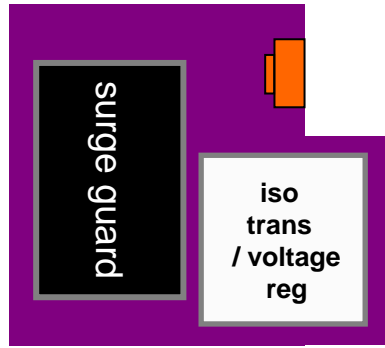
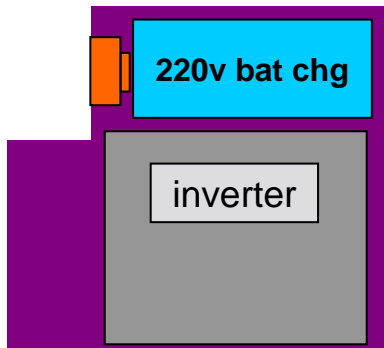
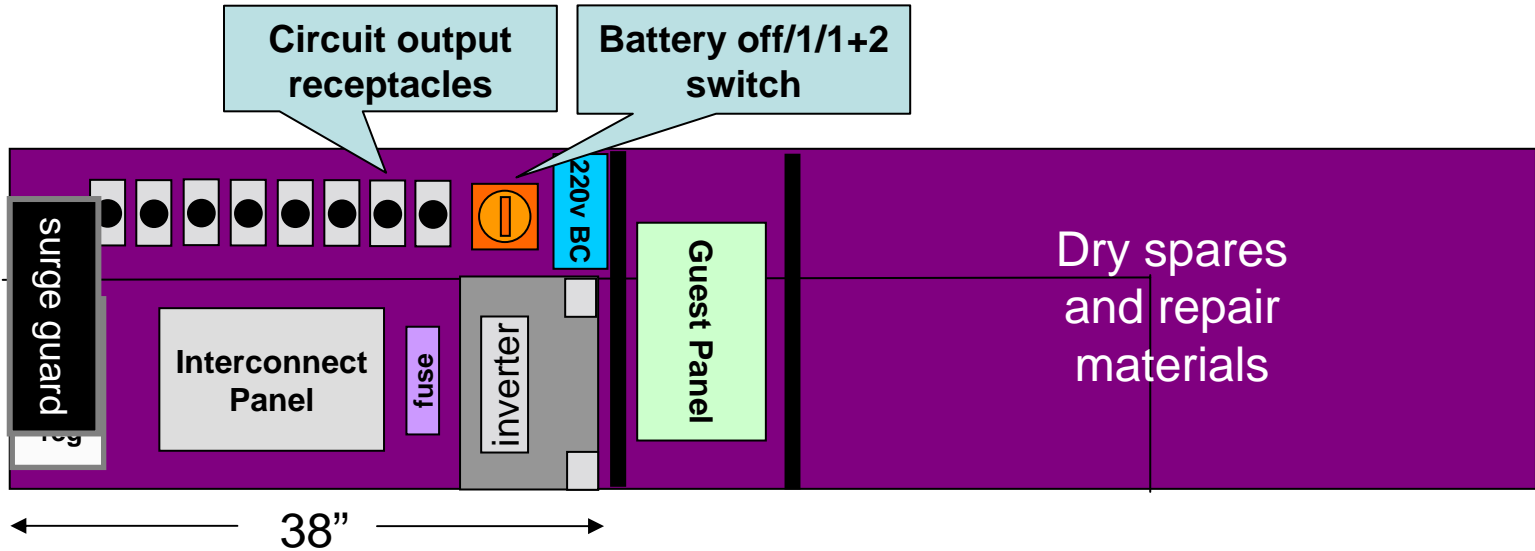

Hackney BEV Chassis Components

Driver's Side Upper Storage Box

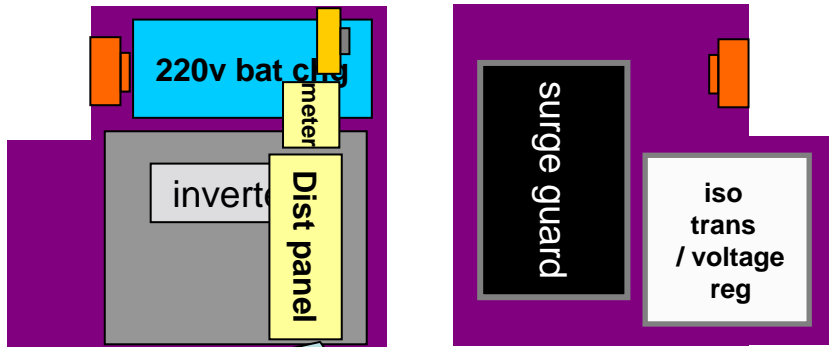
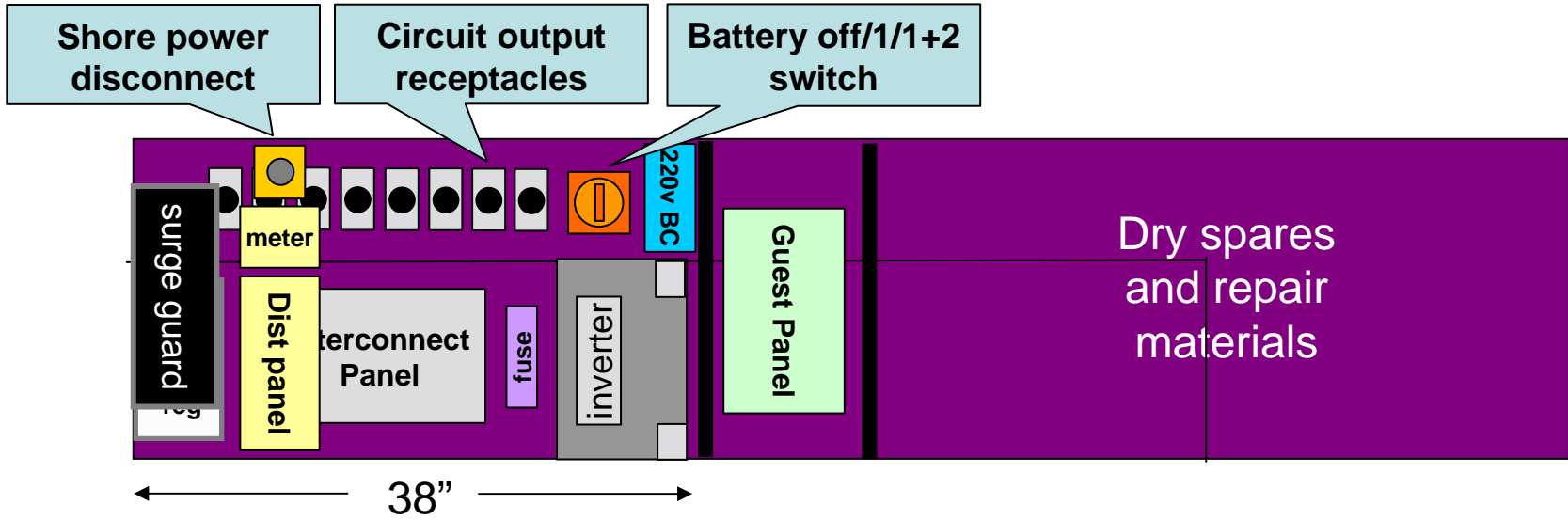

Panels mounted on recessed surface - hinged to allow access to interconnect panel

Hackney BEV Chassis Components

Chassis electrical interconnect panel Chassis to camper entrance

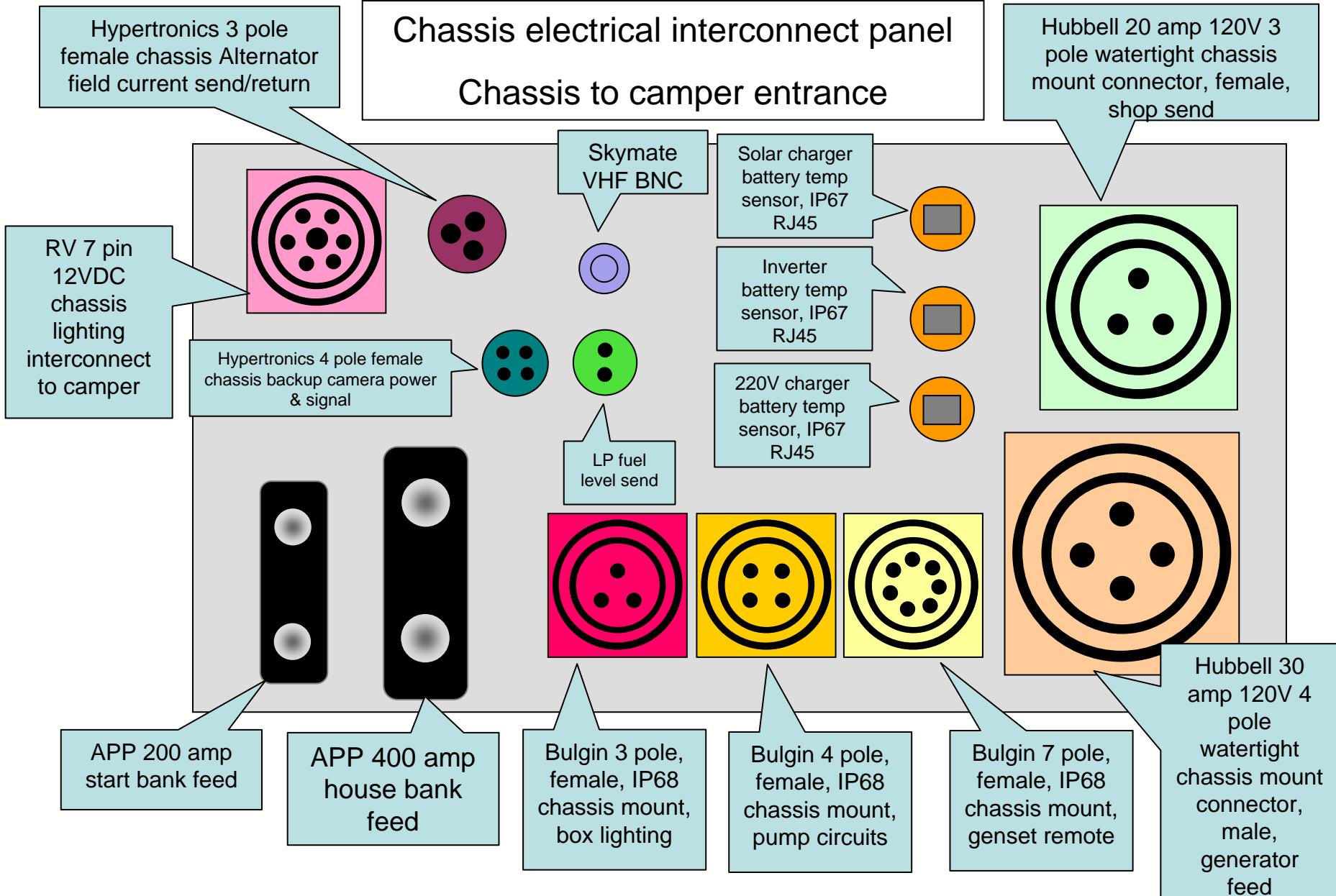

Hackney BEV Chassis Components

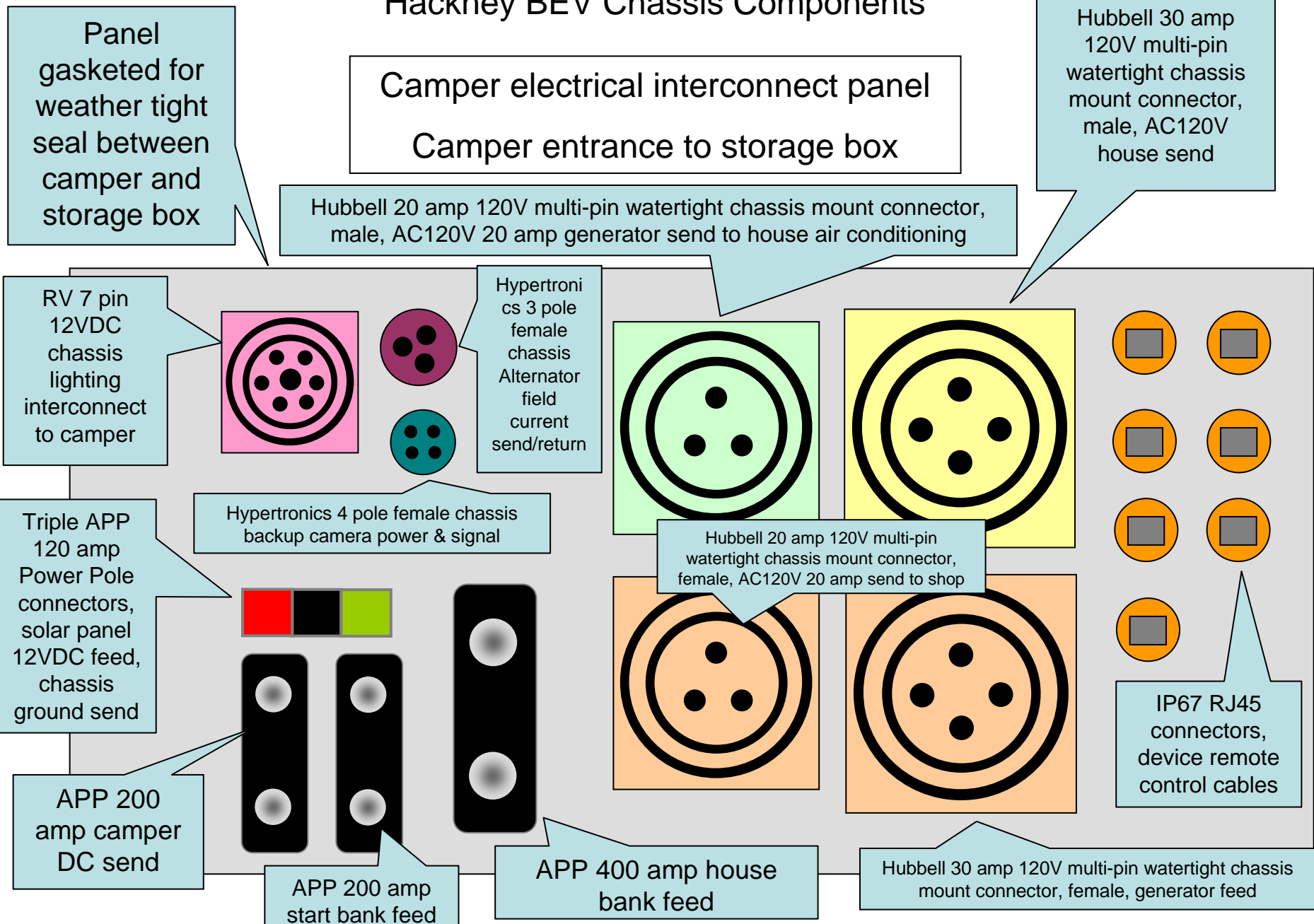

Hackney BEV Chassis Components

Camper Electrical Systems Remote Control Panel

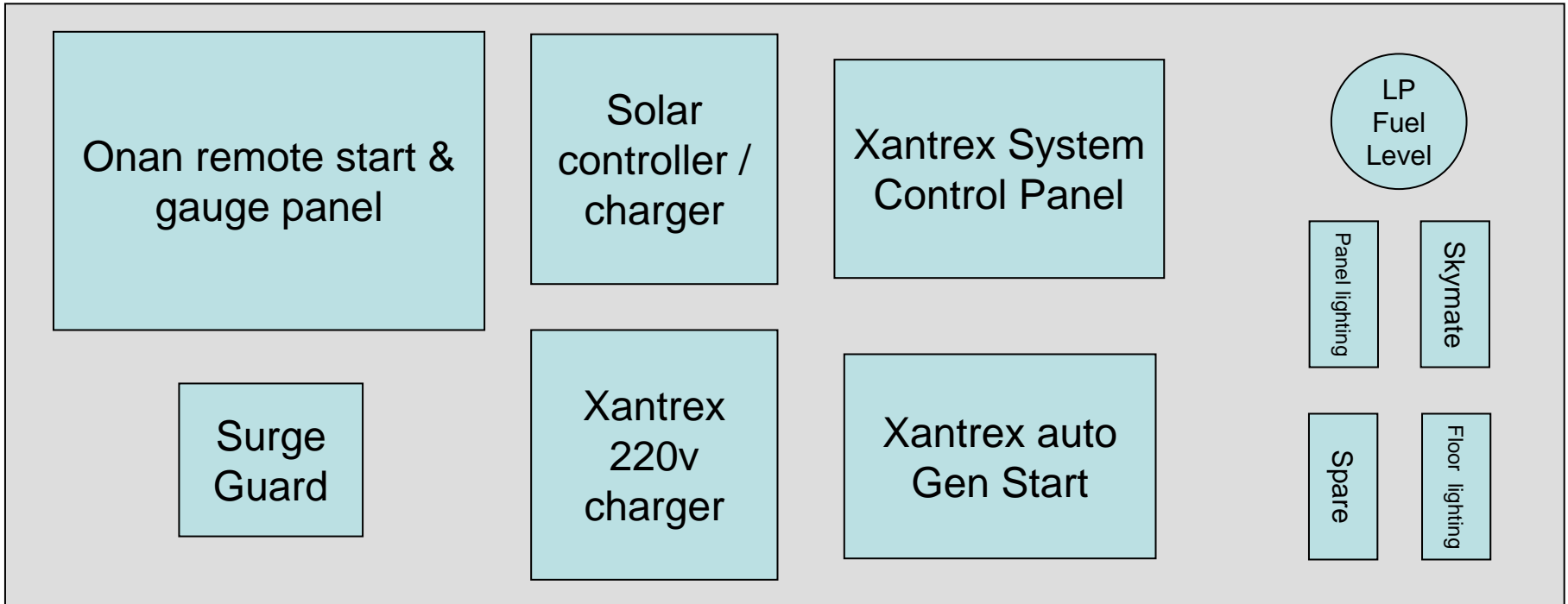

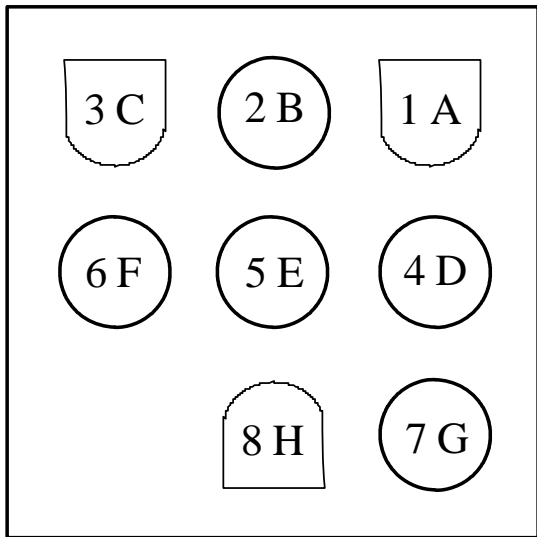

Female

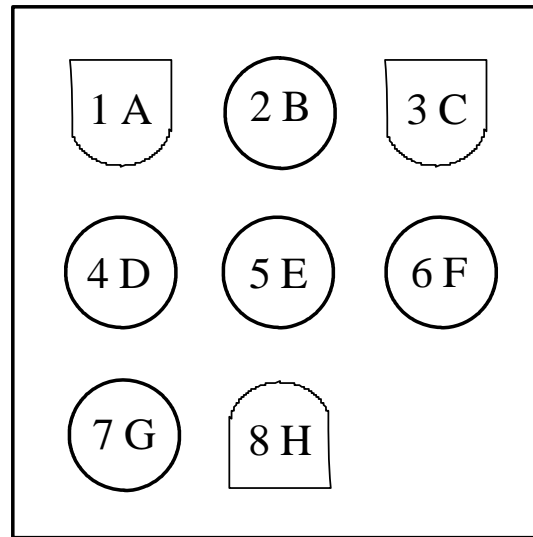

Male

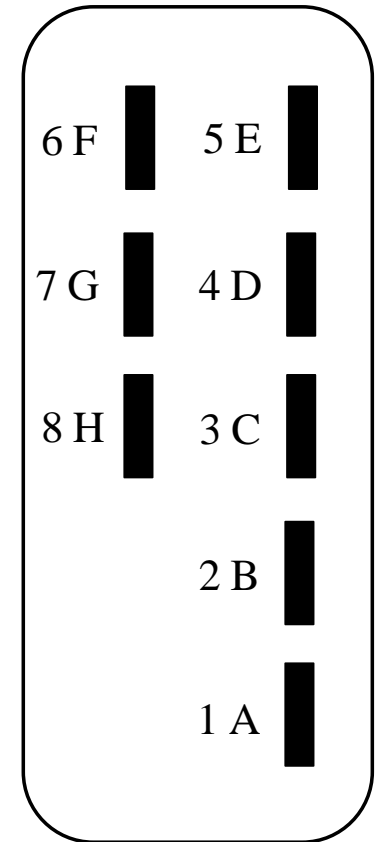

Male

Key	Description
1 A	Ground \perp
2 B	indicator light
3 C	momentary start
4 D	not used
5 E	momentary stop
6 F	+ DC
7 G	oil pressure send
8 H	water temp send

Part #	Description
300-5037	remote control panel
0338-3637	remote panel harness
338-3490-02	genset to remote panel harness

Title: Onan Diesel 7.5 Genset remote control harness pinouts	
Author: Douglas Hackney	
Date: 1 November 2006	Sheet: 1 of 1
Revision: 1.0	Page 27

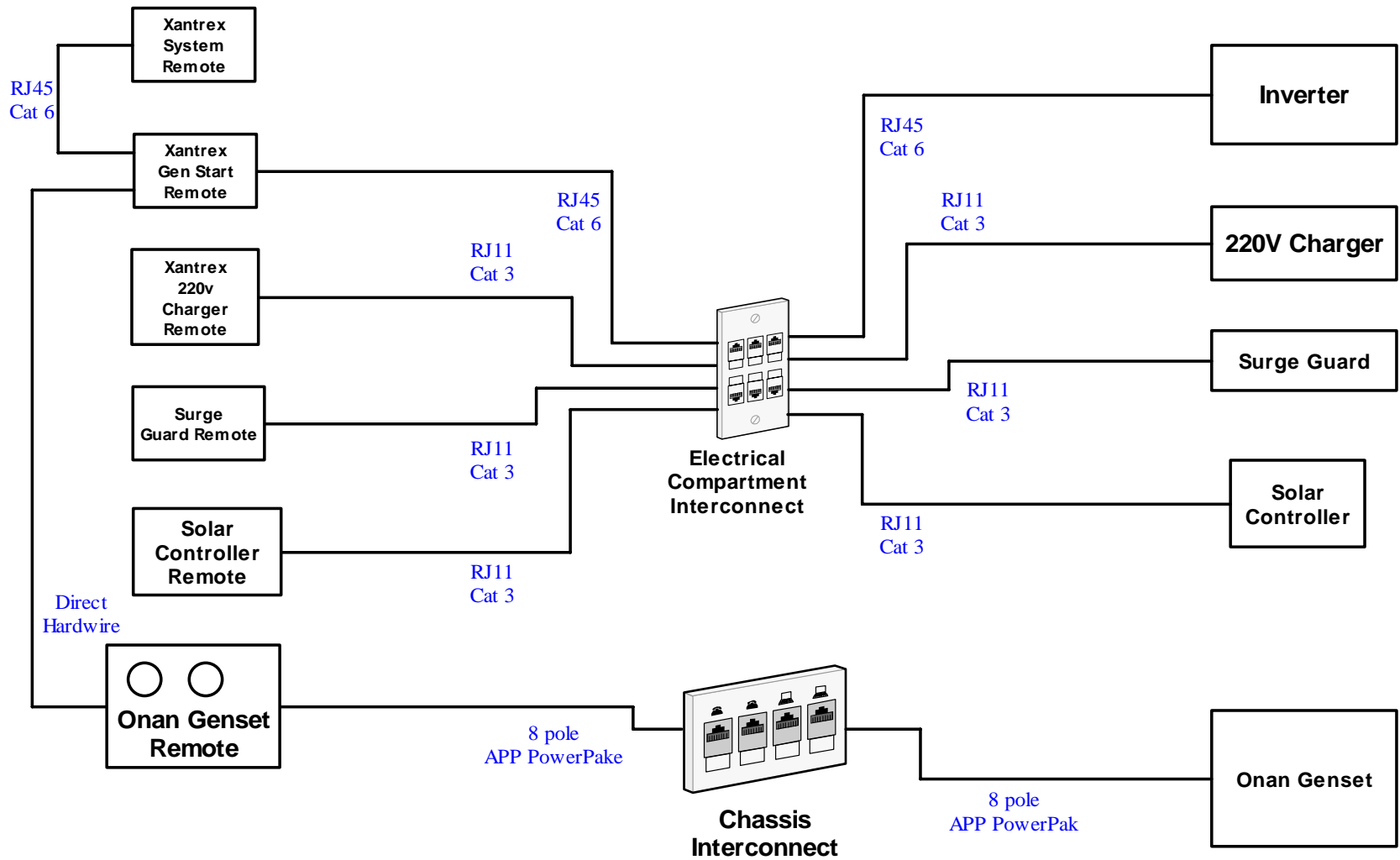

Title: Device Remote Interconnects	
Author: Douglas Hackney	
Date: 22 October 2006	Sheet: 1 of 2
Revision: 1.0	Page 28

Quantity	Description	MFG	Sales	Contact	Model
	Remote Panel Interconnects				
1	DB15 protective cover male	L-Con	L-Con		CVR9F
1	DB15 protective cover female	L-Con	L-Con		CVR9M
4	BNC bulkhead connector, insulated	L-Con	L-Con		BA1089
4	TNC bulkhead connector, insulated	L-Con	L-Con		BA1090
12	IP67 RJ45 bulkhead feed through connector	Woodhead	L-Con		WJP1F5
4	IP67 RJ45 field install plug kit	Woodhead	L-Con		WJAM315
12	IP67 bulkhead connector protective cover with lanyard	Woodhead	L-Con		WJ670300
2	IP67 RJ45 cable 1 meter	Woodhead	L-Con		TRD3115M-1M
1	IP67 RJ45 cable 2 meters	Woodhead	L-Con		TRD3115M-2M
4	IP67 RJ45 cable 4 meters	Woodhead	L-Con		TRD3115M-4M
3	IP67 RJ45 cable 5 meters	Woodhead	L-Con		TRD3115M-5M
2	7 pin panel mount female IP68 - genset remote	Bulgin	Allied Electronics		PX0931/07/S
2	7 pin plug male IP68 - genset remote	Bulgin	Allied Electronics		PXA911/07/P



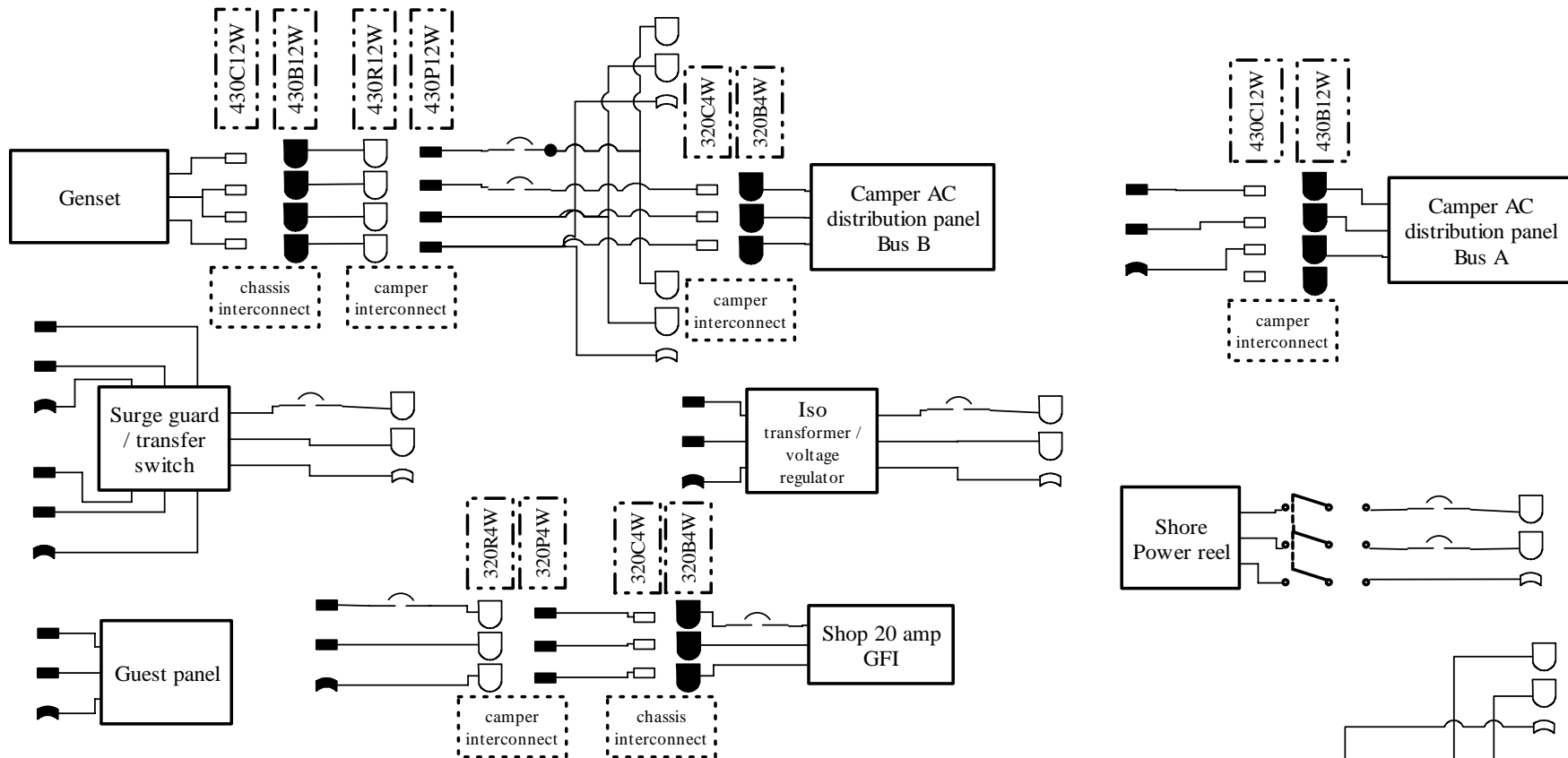

Title: Remote Panel Interconnects BOM	
Author: Douglas Hackney	
Date: 1 November 2006	Sheet: 2 of 2
Revision: 1.1	Page 29

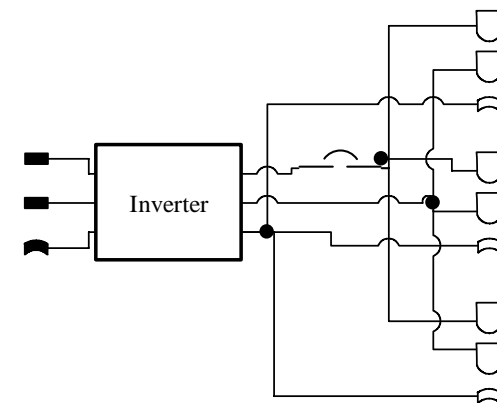
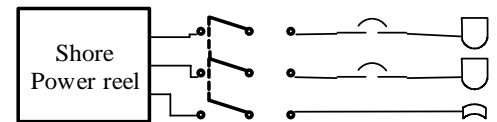

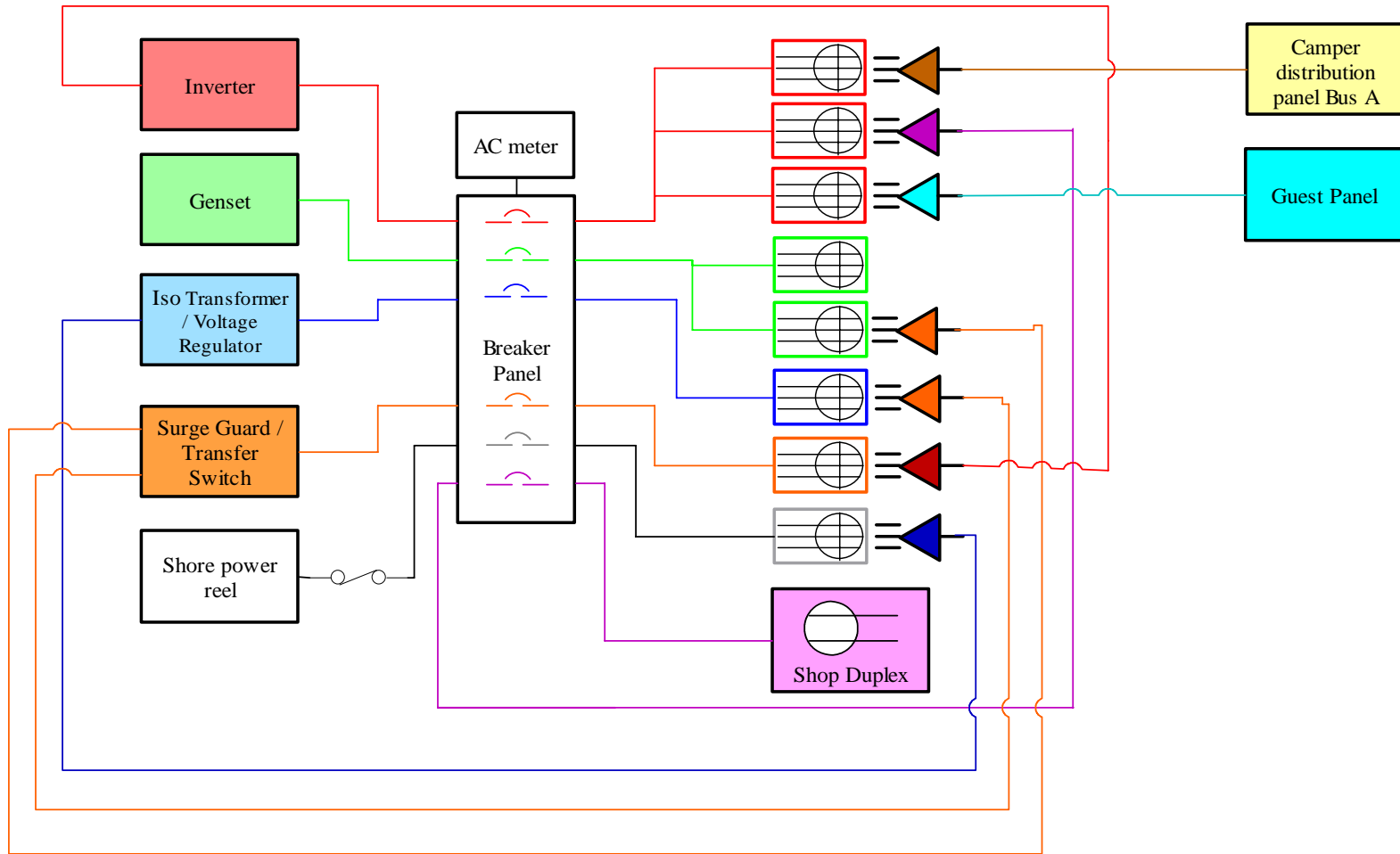
Symbol	Description
	Circuit Breaker
	Male inline connector
	Female chassis connector
	Female inline connector
	Male chassis connector
	Male 30 amp dryer plug
	Female 30 amp dryer receptacle
	30 amp three pole disconnect switch

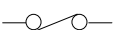





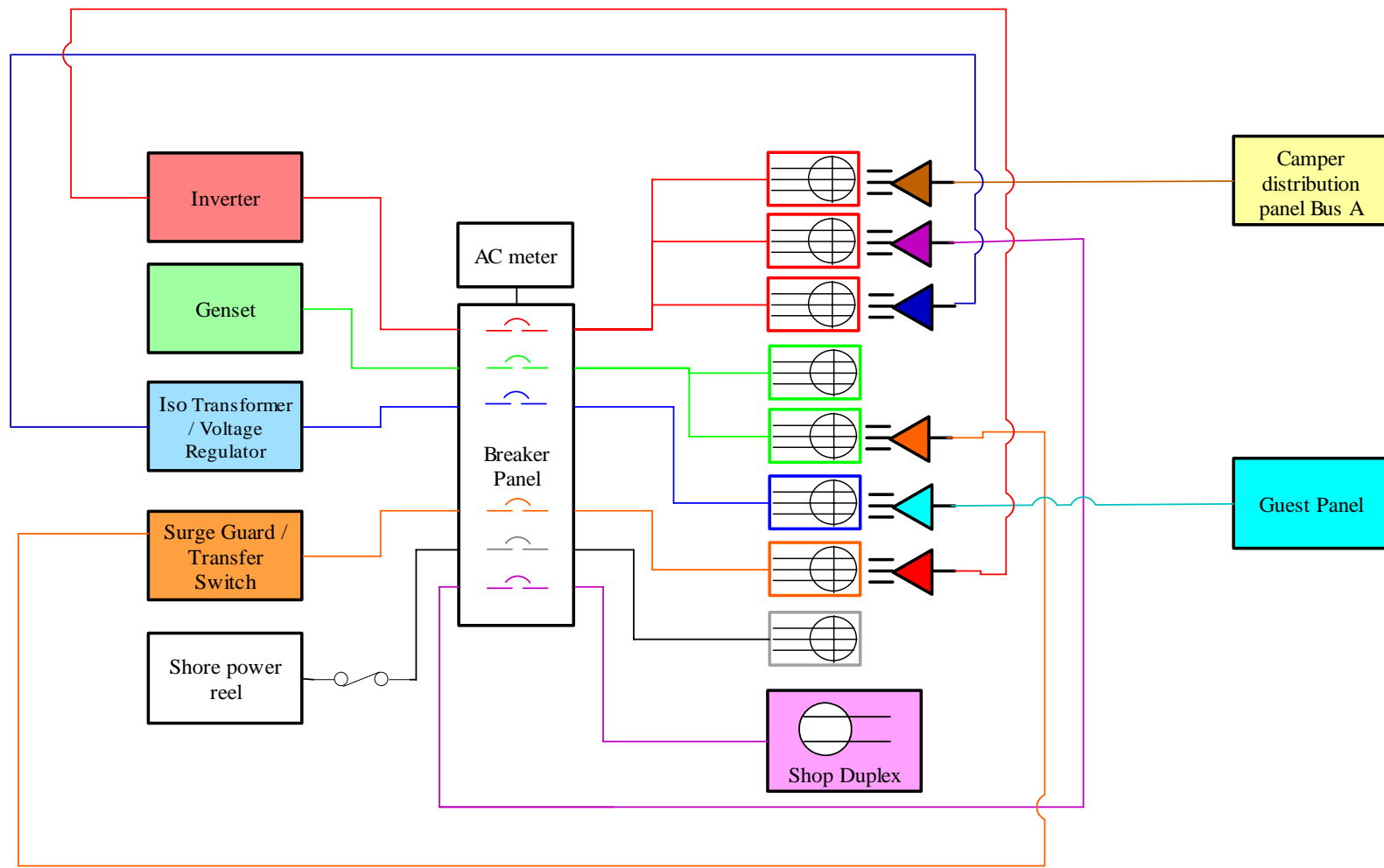

Symbol	Description
	Disconnect switch
	Circuit breaker
	30 amp dryer receptacle
	30 amp dryer plug

Title: AC shore power configuration	
Author: Douglas Hackney	
Date: 4 October 2006	Sheet: 2 of 4
Revision: 1.0	Page 31







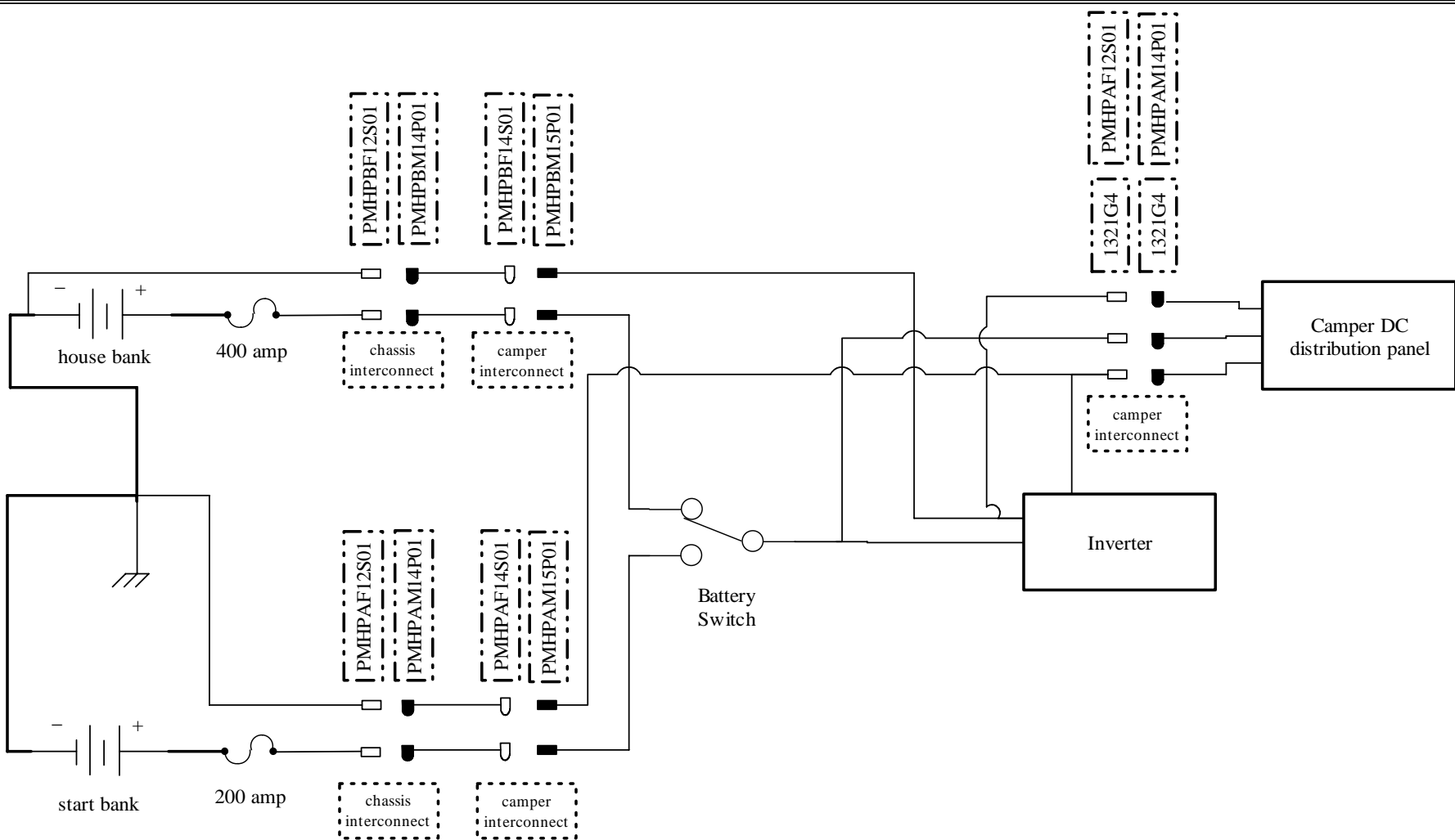

Symbol	Description
	Disconnect switch
	Circuit breaker
	30 amp dryer receptacle
	30 amp dryer plug

Title: ACdry camp - host guest - configuration	
Author: Douglas Hackney	
Date: 4 October 2006	Sheet: 3 of 4
Revision: 1.0	Page 32

Quantity	MFR	Description	Part #
8	Generic	NEMA 10-30R 30 amp dryer receptacle	
8	Generic	NEMA 10-30P 30 amp dryer plug with 6' pigtail	
8	Generic	matching faceplates for dryer receptacles	
8	Generic	plastic duplex boxes for dryer receptacles	
1	Square D	exterior breaker box, 2 breaker slots, 30 amps	
1	Generic	weatherproof 20 amp duplex box	
1	Generic	20 amp receptacle, GFI	
2	Hubbell	30 amp female connector 3 pole 4 wire	HBL430C12W
2	Hubbell	30 amp male inlet 3 pole 4 wire	HBL430B12W
1	Hubbell	30 amp female receptacle 3 pole 4 wire	HBL430R12W
1	Hubbell	30 amp male plug 3 pole 4 wire	HBL430P12W
2	Hubbell	20 amp female connector 2 pole 3 wire	HBL320C4W
2	Hubbell	20 amp male inlet 2 pole 3 wire	HBL320B4W
1	Hubbell	20 amp female receptacle 2 pole 3 wire	HBL320R4W
1	Hubbell	20 amp male plug 2 pole 3 wire	HBL320P4W
6	Blue Sea Sys	20 Amp AC/DC C Breaker single pole	7353
6	Blue Sea Sys	30 Amp AC/DC C Breaker single pole	7355
1	Blue Sea Sys	30 Amp AC C Breaker 2 pole	7365
1	Blue Sea Sys	AC distribution/breaker panel	3480
1	Blue Sea Sys	AC Disconnect 30 amp 4 pole	6337
1	Blue Sea Sys	Panel back circuit breaker insulating covers	4031
1	Blue Sea Sys	DC Digital Voltmeter with alarm	8251
1	Blue Sea Sys	DC Digital Ammeter	8236
1	Blue Sea Sys	AC Digital Voltmeter	8237
1	Blue Sea Sys	AC Digital Frequency Meter	8239
1	Blue Sea Sys	AD Digital Meter Panel	8410
1	Blue Sea Sys	AC Digital Multimeter with alarm	8247
1		Shore Power Reel 30 amp 25' cord	
1	TRC	Surge Guard / transfer switch	40250
1	Charles Marine	Isolation Transformer / Voltage Regulator	93-IXFMR3/8I-A
1	Onan	7500 watt diesel genset pure sine wave	7.5 HDKAJ/11451
1		Guest panel w/30 amp & 20 amp receptables	

Title: ACBOM	
Author: Douglas Hackney	
Date: 4 October 2006	Sheet: 4 of 4
Revision: 1.0	Page 33



Symbol	Description
	Fuse
	Male inline connector
	Female chassis connector
	Female inline connector
	Male chassis connector

Title: BEV high amp DC	
Author: Douglas Hackney	
Date: 31 October	Sheet: 1 of 2
Revision: 1.2	Page 34

Quantity	MFR	Description	Part #
1	Blue Sea Systems	200 Amp Fuse Holder	5007
1	Blue Sea Systems	200 Amp Fuse	5116
1	Blue Sea Systems	400 Amp Fuse Holder	5002
1	Blue Sea Systems	400 Amp Fuse	5121
1	Blue Sea Systems	500 Amp Battery Switch	3003
1	Blue Sea Systems	AC/DC Distribution Panel w/transfer	3086
1	Xantrex	RS3000 inverter	RS3000

Connectors - configuration A / preferred - Anderson Power Products PowerMod HPA / HPB

2	APP	HPA Female inline 2 pole	PMHPAF12S01
2	APP	HPA Male chassis 2 pole	PMHPAM14P01
1	APP	HPA Female chassis 2 pole	PMHPAF14S01
1	APP	HPA Male blind 2 pole	PMHPAM15P01
1	APP	HPA Crimper die	1322G7
2	APP	HPB Female inline 2 pole	PMHPBF12S01
1	APP	HPB Female inline 1 pole	PMHPBF02S01
2	APP	HPB Male chassis 2 pole	PMHPBM14P01
1	APP	HPB Female chassis 2 pole	PMHPBF14S01
1	APP	HPB Male blind 2 pole	PMHPBM15P01
1	APP	HPB Male bus bar 1 pole	PMHPBM04P06
1	APP	HPB Crimper die	1322G14
1	APP	Hydraulic hand crimper	1387G3

Connectors - configuration B / backup - Anderson Power Products PowerPole 180 / 120

9	APP	180 amp connector complete - black	1380G1
8	APP	180 amp connector complete - red	1380G3
1	APP	180 amp bus bar connector	180BBS
9	APP	120 amp housing - red	1321G3
2	APP	120 amp housing - black	1321G1
10	APP	120 amp housing - green	1321G4
11	APP	120 amp connectors #2	1319
10	APP	120 amp connectors #6	1319G6
2	APP	120/180 amp retaining pin 1 high	110G19
16	APP	120/180 amp retaining pin 2 high	110G18
4	APP	2/4 pole mounting bracket	1465G1
2	APP	3/6 pole mounting bracket	1464G2

Title: BEV high amp DC BOM

Author: Douglas Hackney

Date: 4 October 2006

Sheet: 2 of 2

Revision: 1.0

Page 35

house bank
alternator



house bank
voltage regulator

Battery Switch
field disconnect

Pioneer cab
stereo

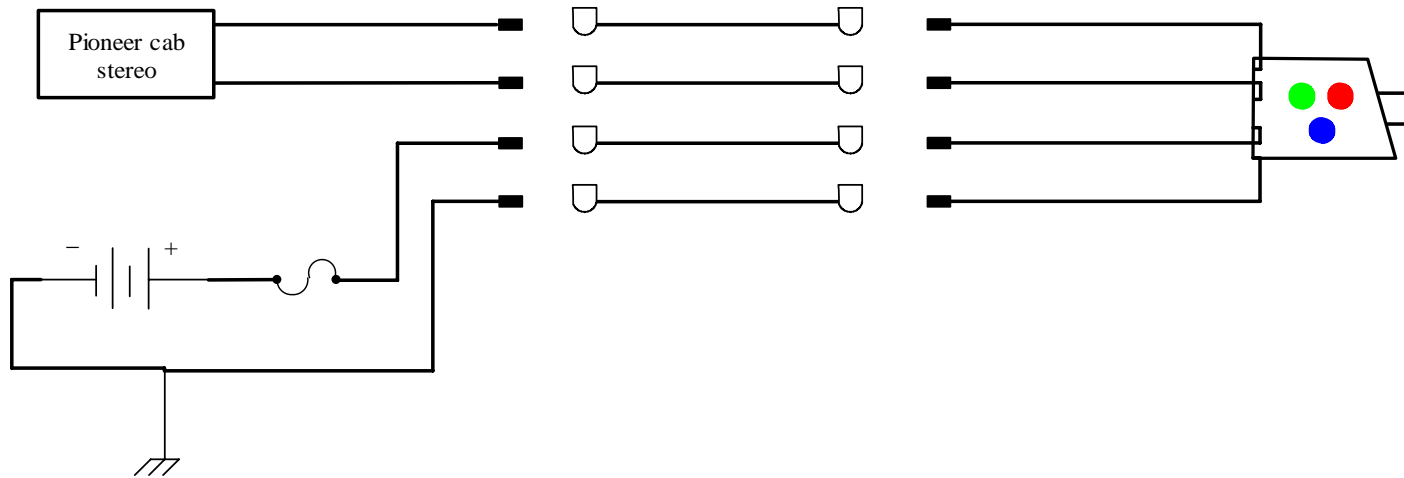
Backup video camera



Symbol	Description
	Fuse
	Male inline connector
	Female chassis connector

Title: BEV lowvoltage / signaling

Author: Douglas Hackney

Date: 4 October 2006

Sheet: 1 of 2

Revision: 1.0

Page 36

MFR:	Hypertronics	
	Sales	Contact
	Kensington Electronics	Karen Perfetto

Quantity	HT #	Description
1	D02EEB315NT	D02 series panel mount 3 pole receptacle housing
3	YSK015-012AH	D02 series solder cup socket 3 pole contact insert
1	D02PB315NT	D02 series male inline plug 3 pole housing
3	YP015-006H (or G)	D02 series solder cup male plug 3 pole insert
1	D01EEB406NT	D01 series panel mount 4 pole receptacle housing
4	YSK006-011AH	D01 series crimp socket 22-26 AWG 4 pole contact insert
1	D01PB406NT	D01 series male inline plug 4 pole housing
4	YPN006-021H (or G)	D01 series crimp pin 22-26 AWG male plug 4 pole insert
2	ZDP100	D01 series color rings
2	ZDP200	D02 series color rings

Title: BEV low voltage / signaling BOM	
Author: Douglas Hackney	
Date: 4 October 2006	Sheet: 2 of 2
Revision: 1.0	Page 37

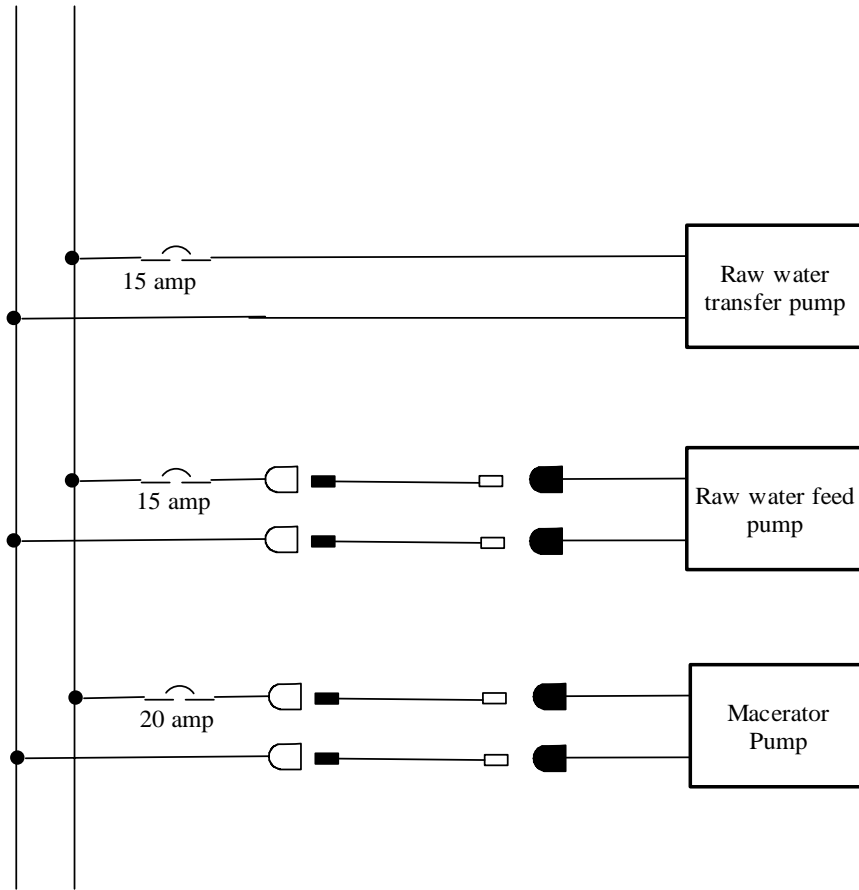

Symbol	Description
	Female chassis
	Male chassis
	Female inline
	Male inline
	Circuit breaker

Title: DC pumps	
Author: Douglas Hackney	
Date: 5 October 2006	Sheet: 1 of 5
Revision: 1.0	Page 38

Quantity	MFR	Description	Part #
1	ShurFlo	7.5 ShurFlo pump	
1	ShurFlo	4.0 ShurFlo pump	
2	Bulgin	4 pin panel mount female IP68 - mac & raw water pump circuits	PX0931/04/S
2	Bulgin	4 pin plug male IP68 - mac & raw water pump circuits	PX0911/04/P

Title: DCpumps BOM	
Author: Douglas Hackney	
Date: 1 November 2006	Sheet: 2 of 5
Revision: 1.1	Page 39

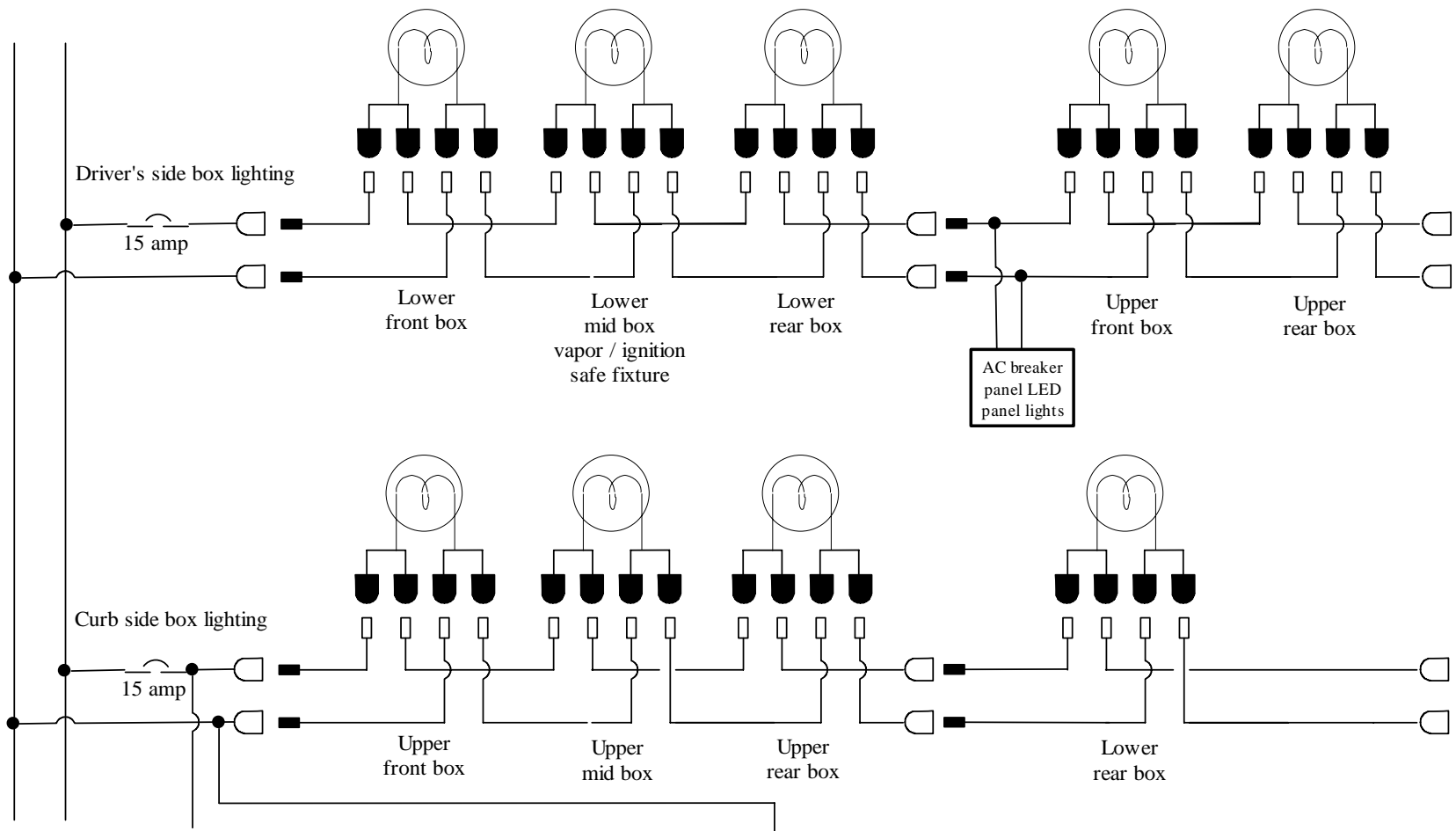

Symbol	Description
	Female chassis
	Male chassis
	Female inline
	Male inline
	Circuit breaker
	Lighting device

Camper lower rear grill box

Title: DC lighting storage boxes	
Author: Douglas Hackney	
Date: 5 October 2006	Sheet: 3 of 5
Revision: 1.0	Page 40

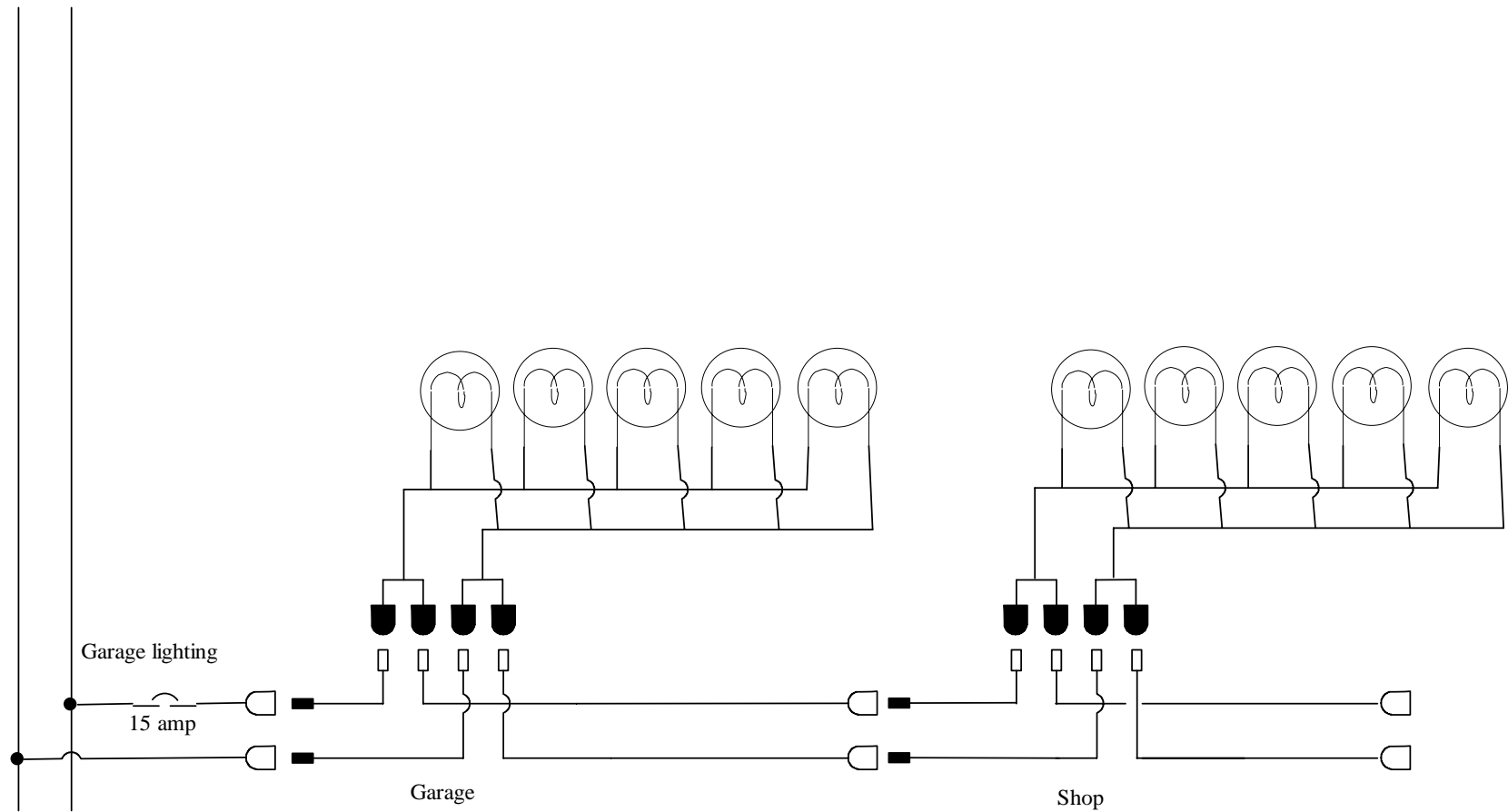

Symbol	Description
	Female chassis
	Male chassis
	Female inline
	Male inline
	Circuit breaker
	Lighting device

Title: DC lighting shop & garage	
Author: Douglas Hackney	
Date: 5 October 2006	Sheet: 4 of 5
Revision: 1.0	Page 41

Quantity	MFR	Description	Part #
2	Bulgin	7 pin panel mount female IP68 - genset remote	PX0931/07/S
2	Bulgin	7 pin plug male IP68 - genset remote	PXA911/07/P
2	Bulgin	4 pin panel mount female IP68 - mac & raw water pump circuits	PX0931/04/S
2	Bulgin	4 pin plug male IP68 - mac & raw water pump circuits	PX0911/04/P
2	Bulgin	3 pin panel mount female IP68 - box lighting circuits	PX0931/03/S
2	Bulgin	3 pin plug male IP68 - box lighting circuits	PX0911/03/P
4	Bulgin	receptacle covers	PX0960
4	Bulgin	plug covers	PX0970
4	Bulgin	cable size inserts	PX0980
1	Blue Sea Systems	AC/DC Distribution Panel w/transfer	3086
2	Blue Sea Systems	20 Amp AC/DC C Breaker single pole	7353
6	Perko	dome light with switch 6"	PKO#1253DP2
6	Perko	dome light with switch 5"	PKO#1253DP1

Title: DC lighting BOM	
Author: Douglas Hackney	
Date: 1 November 2006	Sheet: 5 of 5
Revision: 1.1	Page 42

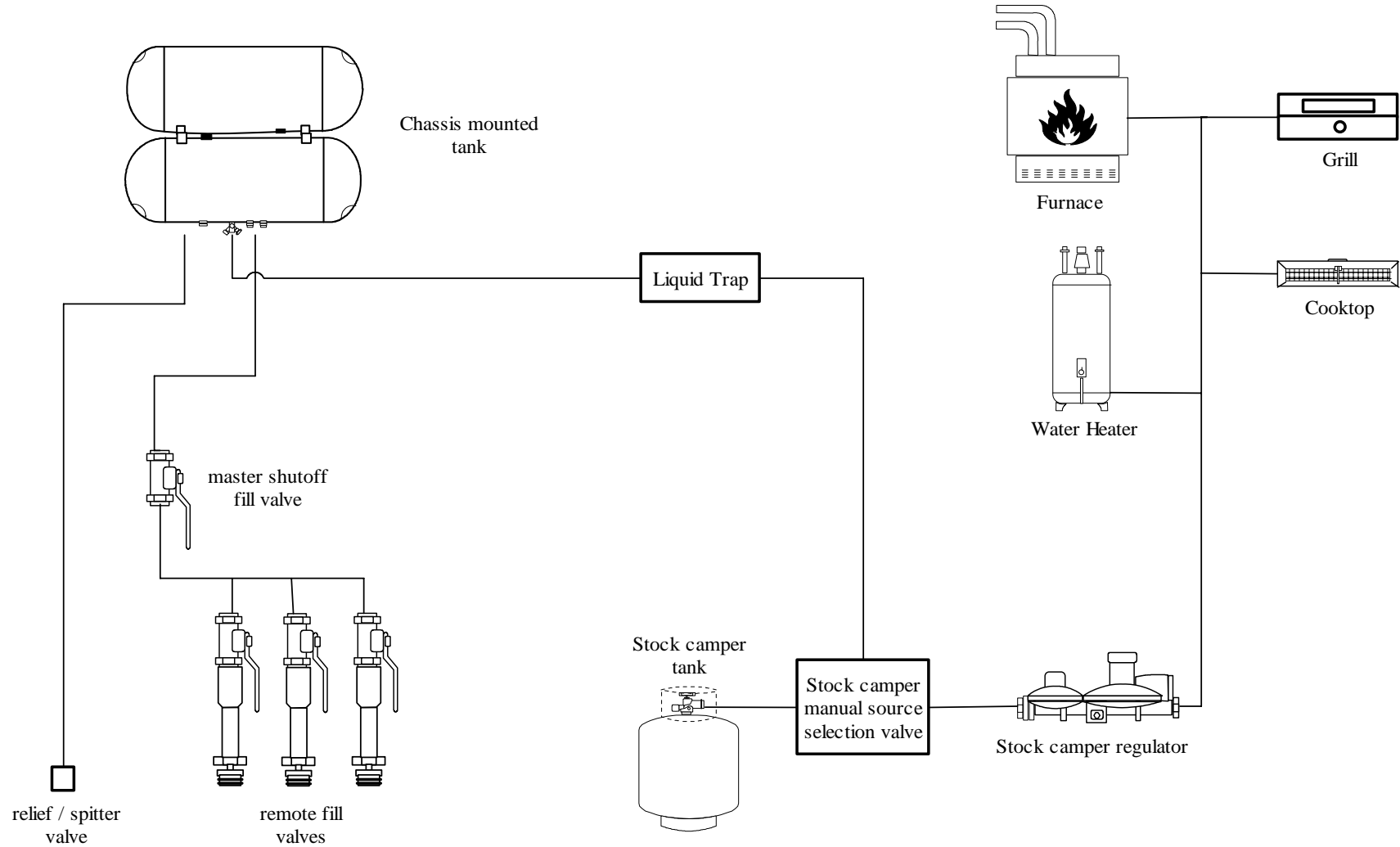

Title: Propane / LP	
Author: Douglas Hackney	
Date: 5 October 2006	Sheet: 1 of 2
Revision: 1.0	Page 43

Quantity	Description	MFG	Sales	Contact	Model
1	LP tanks	Sleeper Eng.	Sleeper Eng.		
1	LP remote guage				
	LP high pres hose				
	LP low pres hose				
	LP fittings				
	Rego				
1	1/2" F NPT	Rego			7647HF
1	1/2" flare SAE	Rego			7647H
1	1 3/4" M ACME & F POL	Rego	LPG & NH3 Supply, Inc.	Charlie Koch	7647DC
1	1 3/4" M ACME	Rego	LPG & NH3 Supply, Inc.	Charlie Koch	7647SC
	Rotarex LPG-TEC				
	bulk filler valve (European)				
1	1 1/4" M NPT				A400
1	1 1/4" M NPT				A402
	tank multi valves (international)				
1	Europe acc to NBN/NEN/DIN (input male)				A201
1	France acc to NF (input male)				A206
1	no designation acc to ASA/CGA (input female)				A225
1	South America acc to ASA/CGA (input female)				A226
1	Germany/Austria acc to DIN 477 (input male)				A301
1	Germany/Austria acc to DIN 477 (input male)				A305
1	Scandinavia acc to DIN/ASA (input female)				A343
1	ACME female for field adapters				
1	POL male for field adapters				
1	Various brass NPT fittings for field adapters				

Title: Propane BOM

Author: Douglas Hackney





Date: 5 October 2006

Sheet: 2 of 2

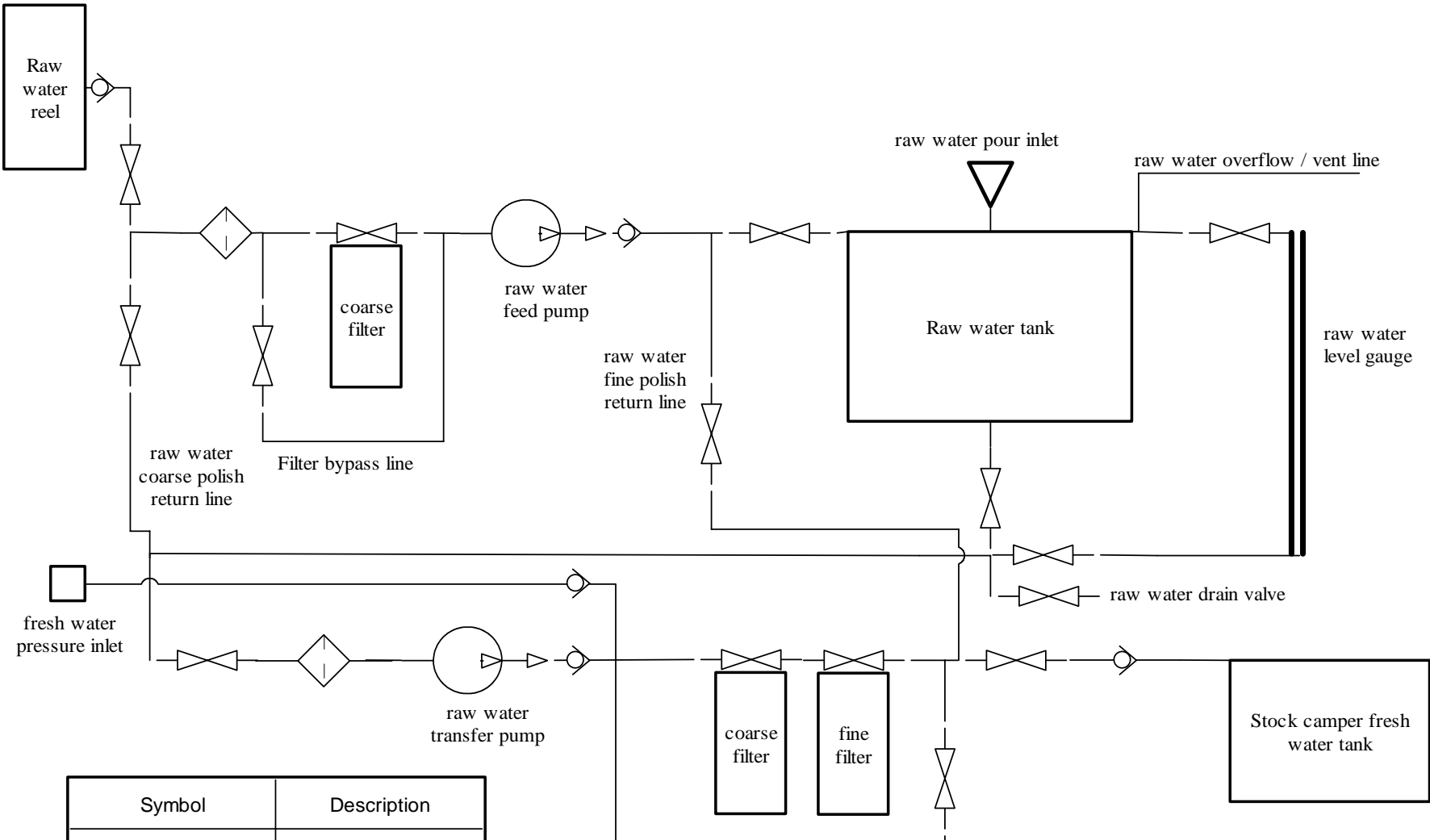
Revision: 1.0

Page 44

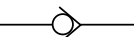

Symbol	Description
	valve
	Sediment filter
	Pump
	Clear hose
	Check Valve

Title: Water	
Author: Douglas Hackney	
Date: 28 October 2006	Sheet: 1 of 2
Revision: 1.3	Page 45

Quantity	Description	MFG	Sales	Contact	Model
1	Raw water reel with hose				
2	SureFlo sediment filter	SureFlo			
1	SureFlo 7.5 pump	SureFlo			
1	SureFlo 4.0 pump	SureFlo			
2	SureFlo barb adapters straight	SureFlo			
2	SureFlo barb adapters 90	SureFlo			
2	coarse filter				
1	fine filter				
1	UV array				
1	rinforced 1/2" ID hose 150'				
17	valves				
1	assorted elbows, unions, etc.				
5	check valves				

Title: Water BOM	
Author: Douglas Hackney	
Date: 28 October 2006	Sheet: 2 of 2
Revision: 1.1	Page 46

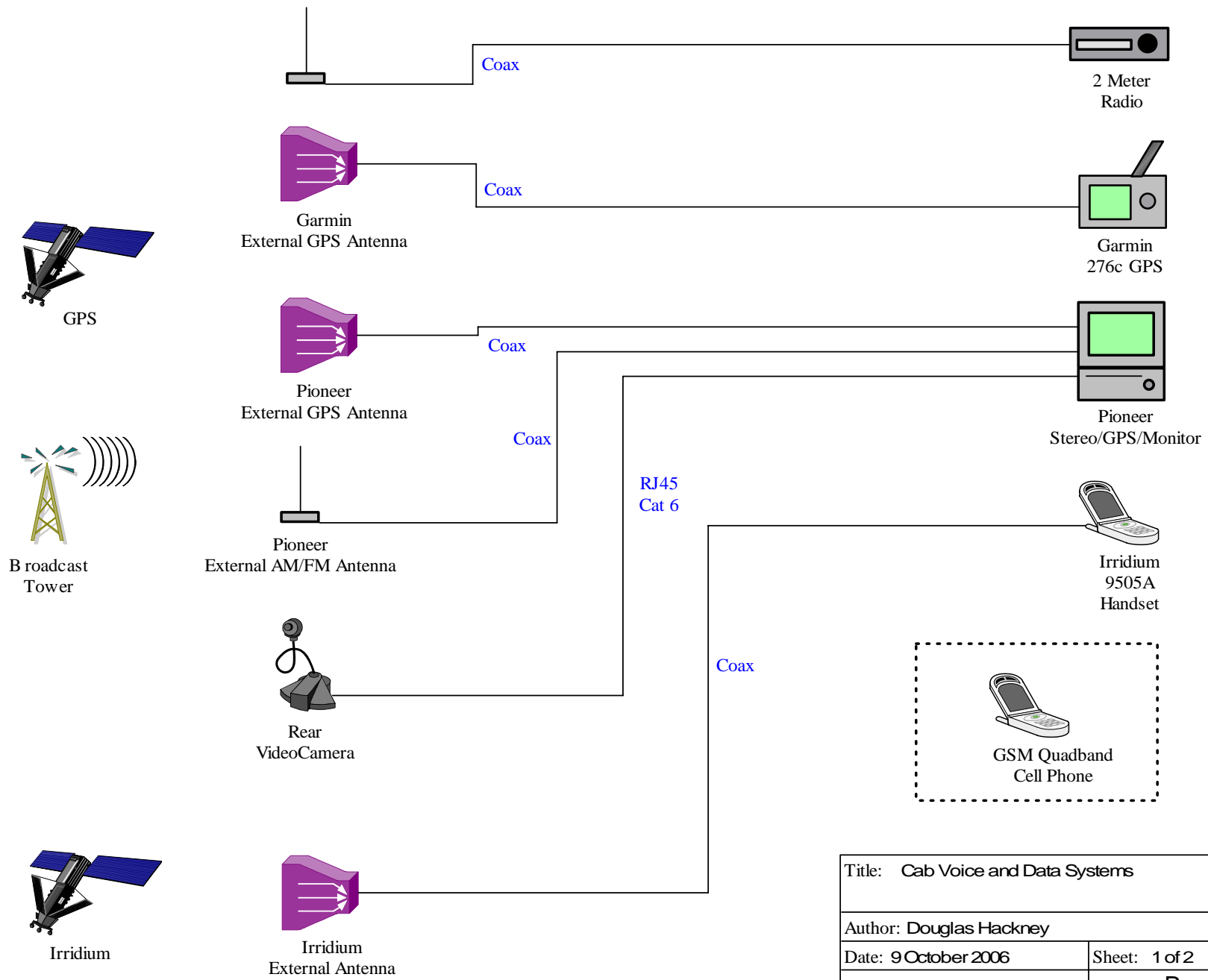

Title: Cab Voice and Data Systems	
Author: Douglas Hackney	
Date: 9 October 2006	Sheet: 1 of 2
Revision: 1.0	Page 47

Quantity	Description	MFG	Sales	Contact	Model
	Cab Voice & Data				
1	Garmin 276c GPS				
1	Garmin 276c external GPS antenna				
1	Garmin 276c external GPS antenna to phone cable				
1	Iridium 9505A external antenna				
1	Iridium 9505A external antenna to phone cable				
1	Pioneer Stereo w/video monitor & GPS				
1	Pioneer Stereo external GPS antenna				
1	Pioneer Stereo external GPS antenna cable				
1	Rear video camera				
1	Rear video camera to Pioneer cable				
1	2 meter radio				
1	2 meter radio antenna				
1	2 meter radio antenna cable				
1	overhead console				

Title: Data and Voice Systems Cab BOM

Author: Douglas Hackney

Date: 10 October 2006

Sheet: 2 of 2

Revision: 1.0

Page 48

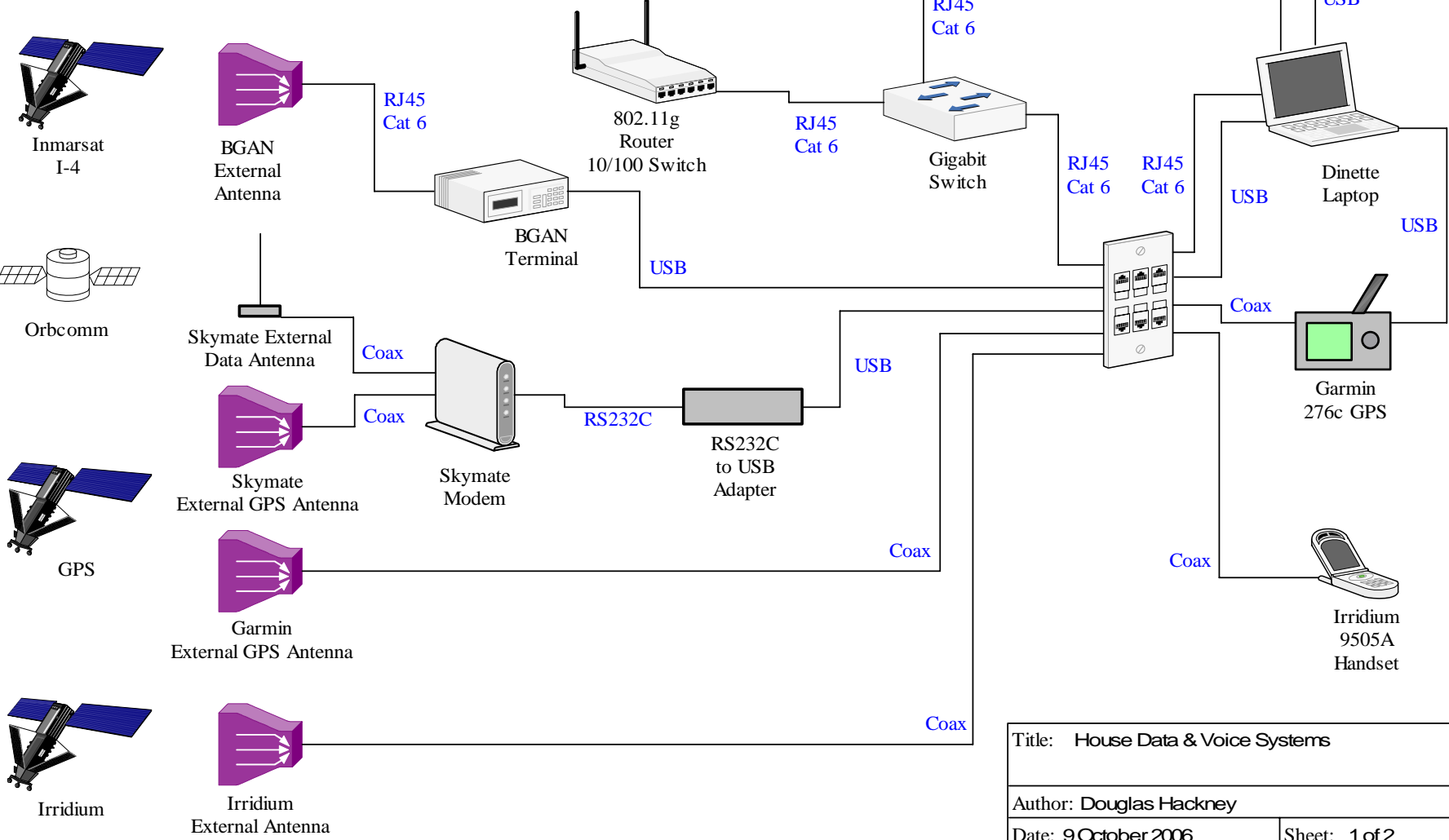
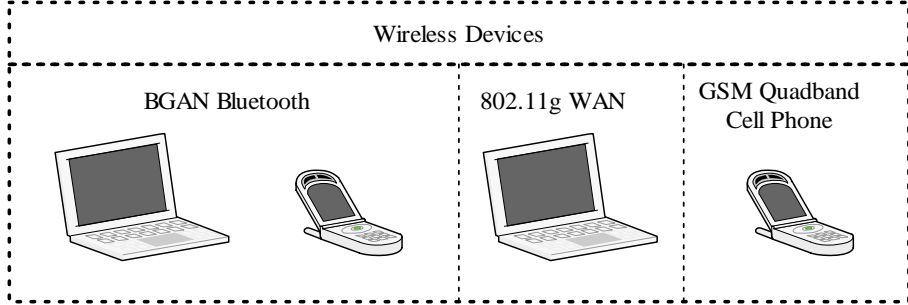

Title: House Data & Voice Systems	
Author: Douglas Hackney	
Date: 9 October 2006	Sheet: 1 of 2
Revision: 1.0	Page 49

Quantity	Description	MFG	Sales	Contact	Model
	House Voice & Data				
1	Surge protected outlet strip	Generic			
1	BGAN Terminal	Nera			WorldPro 1000/1010
	BGAN Terminal extra battery	Nera			102207
	BGAN Terminal auto plug DC adapter	Nera			107572
1	BGAN Antenna	Nera			WorldPro 1000/1010
1	BGAN Bluetooth handset	Tenovis			107774
1	BGAN Antenna mount bracket	Generic			108409
	BGAN Antenna mount ball head	Generic			108424
1	BGAN Antenna to terminal cable	Nera			106495
1	802.11G AP/Router/Switch	Linksys			
1	Gigabit workgroup switch	Linksys			
1	Patch switchplate				
3	RJ45 patch points				
2	Coax patch points				
1	USB patch points				
1	RAID 5 NAS 2TB data array	Buffalo	CDW		
1	Spare 500 GB drive	Buffalo	CDW		
1	Flatbed scanner	Canon			
1	Compact color inkjet printer				
1	Skymate external data antenna	SkyMate	Custom Marine Electronics		SkyMate 200 Sentry Mate
1	Skymate data antenna / modem cable	SkyMate	Custom Marine Electronics		SkyMate 200 Sentry Mate
1	Skymate external GPS antenna	SkyMate	Custom Marine Electronics		SkyMate 200 Sentry Mate
1	Skymate GPS antenna / modem cable	SkyMate	Custom Marine Electronics		SkyMate 200 Sentry Mate
1	Skymate modem	SkyMate	Custom Marine Electronics		SkyMate 200 Sentry Mate
1	RS232C to USB adapter	SkyMate	Custom Marine Electronics		SkyMate 200 Sentry Mate
1	Garmin 276c external GPS antenna	Garmin	Garmin		
1	Garmin 276c external GPS antenna to phone cable	Garmin	Garmin		
1	Iridium 9505A external antenna				
1	Iridium 9505A external antenna to phone cable				
1	Iridium 9505A antenna adapter				
1	Iridium 9505A high capacity extra battery				
1	Iridium 9505A cigarette lighter adapter				
1	Pelican series case				
1	Iridium 9505A handset				

Title: House Data and Voice Systems BOM

Author: Douglas Hackney

Date: 10 October 2006

Sheet: 2 of 2

Revision: 1.0

Page 50

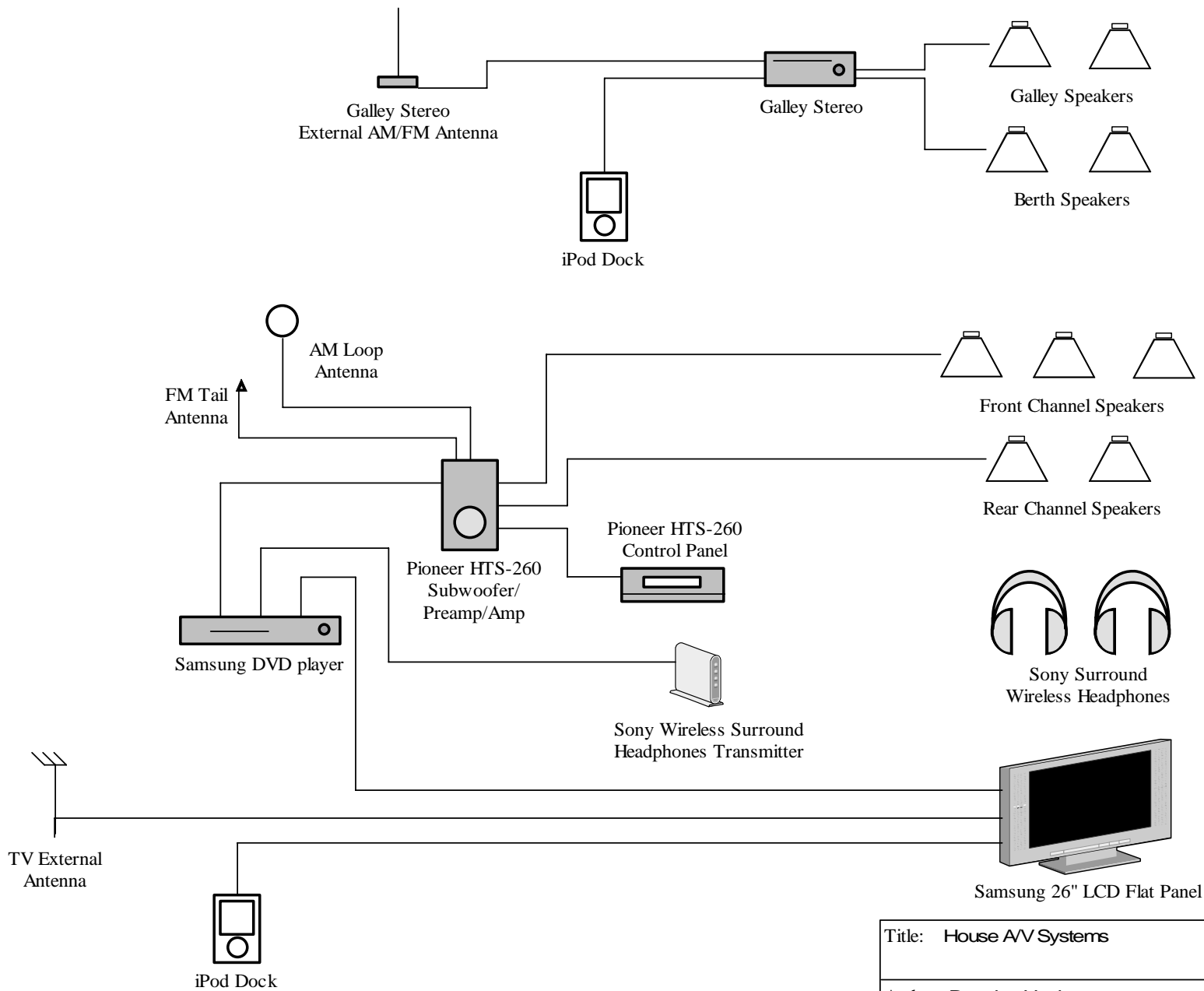

Title: House AV Systems	
Author: Douglas Hackney	
Date: 9 October 2006	Sheet: 1 of 2
Revision: 1.0	Page 51

Quantity	Description	MFG	Sales	Contact	Model
	House AV Systems				
1	Galley Stereo				
1	Galley Stereo external antenna to stereo cable				
1	Galley Stereo iPod dock				
1	Berth surround sound system	Pioneer	Amazon		HTS-260
1	DVD Player	Samsung	Amazon		HD 960
1	Flat Panel TV	Samsung	Best Buy		LN-S2651D
1	iPod Dock	Samsung	Samsung		BN96-03624A
1	Wireless surround headphones	Sony			
1	TV external antenna				
1	TV external antenna to TV cable				

Title: House AV System BOM	
Author: Douglas Hackney	
Date: 10 October 2006	Sheet: 2 of 2
Revision: 1.0	Page 52

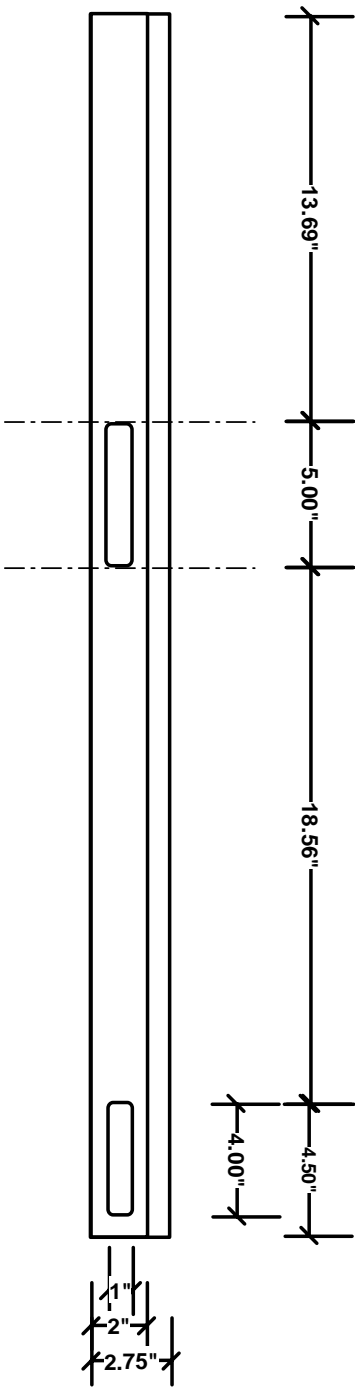
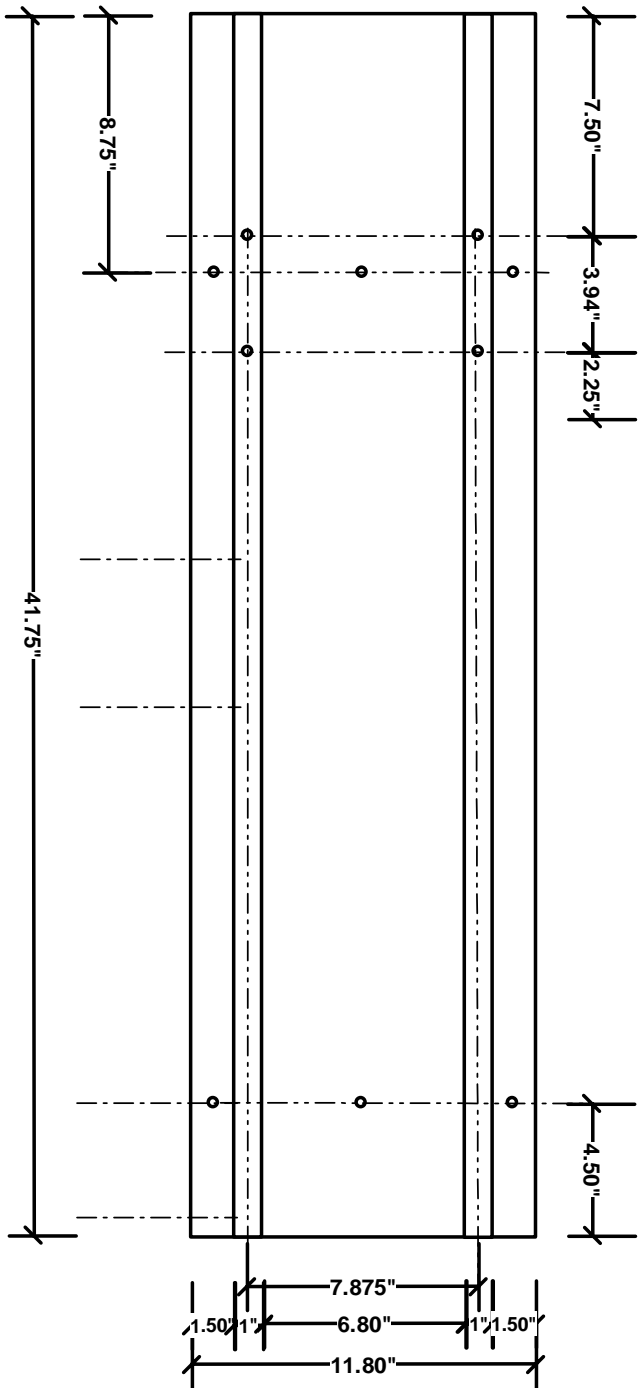

TV wall mount for Bigfoot 30C10.11FR
camper bunk wall. Suitable for any
100x200mm flat panel TV.

Material: Aluminum of sufficient
stock to support 23 lbs.
Finish: Gloss Black Powdercoat

Title: TV wall mount front and side view	
Author: Douglas Hackney	
Date: 18 October 2006	Sheet: 1 of 2
Revision: 1.2	Page 53

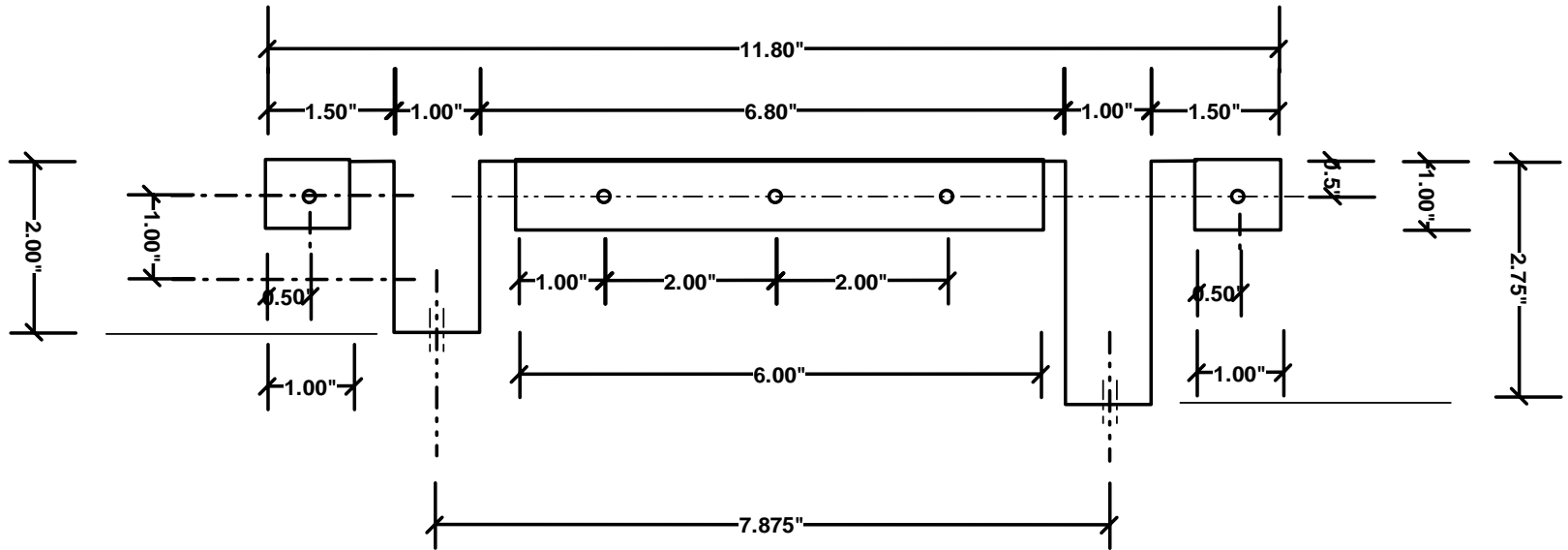

Top and Bottom views are identical
 Mounting tabs on top and bottom
 Note different depths of boxout sections

Material: Aluminum of sufficient stock to support 23 lbs.
 Finish: Gloss Black Powderdercoat

Panel section
 with mounting tab

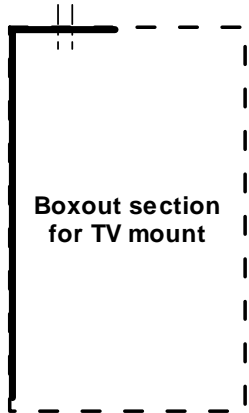

Boxout section
 for TV mount

TV wall mount for Bigfoot 30C10.11FR
 camper bunk wall. Suitable for any
 100x200mm flat panel TV.

Title: TV mount top view	
Author: Douglas Hackney	
Date: 18 October 2006	Sheet: 2 of 2
Revision: 1.2	Page 54

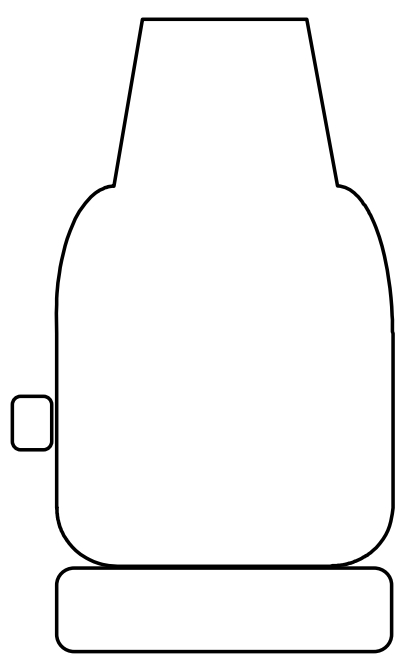

41.0"
9.4"

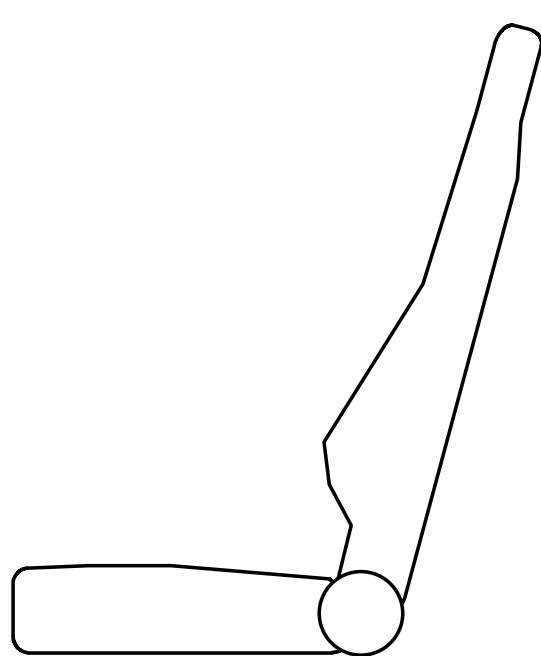

9.4"
19.0"
35.0"
41.0"
20.0"

2.0"
19.0"
21.0"

19.0"

Title: 2007 Mitsubishi Fuso FG stock seat	
Author: Douglas Hackney	
Date: 1 November 2006	Sheet: 1 of 1
Revision: 1.0	Page 55

Hackney BEV Chassis Components

NATIONAL SEATING CO. VANDERBILT, TN.

PART NUMBER	DESCRIPTION
00452_51	HIBAC PREMIUM GREY/SMOKE LTHR
00452_151	HIBAC PREMIUM GREY/SMOKE LTHR LH ARMREST
00452_251	HIBAC PREMIUM GREY/SMOKE LTHR RH ARMREST
00452_54	HIBAC PREMIUM BROWN/TAN LTHR
00452_154	HIBAC PREMIUM BROWN/TAN LTHR LH ARMREST
00452_254	HIBAC PREMIUM BROWN/TAN LTHR RH ARMREST
00452_55	HIBAC PREMIUM BLACK/GRAY LTHR
00452_155	HIBAC PREMIUM BLACK/GRAY LTHR LH ARMREST
00452_255	HIBAC PREMIUM BLACK/GRAY LTHR RH ARMREST
00452_56	HIBAC PREMIUM BLACK/BLACK LTHR
00452_156	HIBAC PREMIUM BLACK/BLACK LTHR LH ARMREST
00452_256	HIBAC PREMIUM BLACK/BLACK LTHR RH ARMREST
00452_156H	HIBAC PREMIUM BLACK/BLACK LTHR LH ARMREST & HEATER
00452_256H	HIBAC PREMIUM BLACK/BLACK LTHR RH ARMREST & HEATER
00452_61	HIBAC PREMIUM GREY MORDURA
00452_161	HIBAC PREMIUM GREY MORDURA LH ARMREST
00452_261	HIBAC PREMIUM GREY MORDURA RH ARMREST
00452_64	HIBAC PREMIUM BROWN MORDURA
00452_164	HIBAC PREMIUM BROWN MORDURA LH ARMREST
00452_264	HIBAC PREMIUM BROWN MORDURA RH ARMREST
00452_65	HIBAC PREMIUM BLACK MORDURA
00452_165	HIBAC PREMIUM BLACK MORDURA LH ARMREST
00452_265	HIBAC PREMIUM BLACK MORDURA RH ARMREST
00452_157B	HIBAC PREMIUM TAN LEATHER LH ARMREST & BACK CYCLER
00452_257B	HIBAC PREMIUM TAN LEATHER RH ARMREST & BACK CYCLER

- NOTES:
- 1) H POINT MEASUREMENT IS TAKEN WITH BACK RECLINE FULL FORWARD, TRACK ADJUSTED TO REAR POSITION.
 - 2) SEAT EQUIPPED WITH TRIPLE CHAMBER AIR LUMBAR AND BOLSTERS.

STATEMENT OF COMPLIANCE

THIS SEAT HAS BEEN TESTED TO THE APPLICABLE D.O.T. SPECIFICATIONS OF FEDERAL MOTOR VEHICLE SAFETY STANDARD 207 AND WILL SURPASS THE LOAD REQUIREMENTS STATED THEREIN. COMPLIANCE BASED ON REGULATIONS IN EFFECT AT TIME OF MANUFACTURE.

THE MATERIAL IN THIS SEAT AS ORIGINALLY MANUFACTURED CONFORMS TO THE REQUIREMENTS OF F.M.V.S.S. 302.

NOTE: REF. DIMENSIONS PROVIDED FOR PRODUCT IDENTIFICATION PURPOSES. ALL REF. DIMENSIONS ARE TO DESIGN NOMINAL AND TO UNTRIMMED SEATS. CUSTOMER TRIM VARIATIONS WILL AFFECT DIMENSION POINTS ON FINISHED SEATS.

BLACK POWDER COAT FINISH TO ADHERE TO FOLLOWING SPECS.

CHARACTERISTIC	METHOD	REQUIREMENT
HUMIDITY	ASTM D 4584	ASTM D714 8 MEDIUM OR BETTER
ADHESION	ASTM D 3359 B	MIN. 4B
HARDNESS	ASTM D 3363	2 HOURS OR BETTER

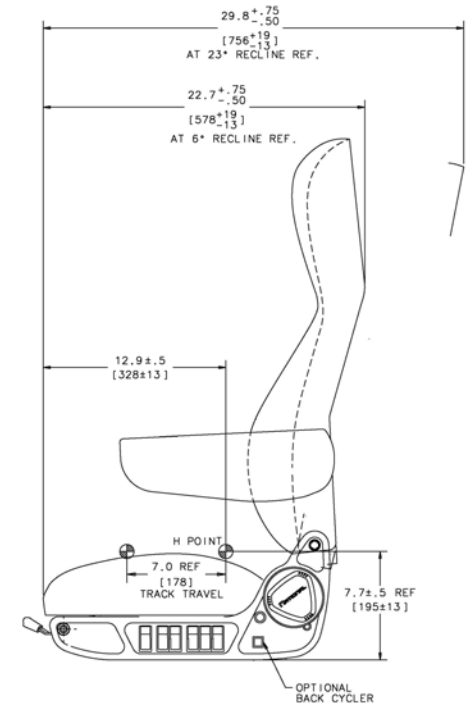
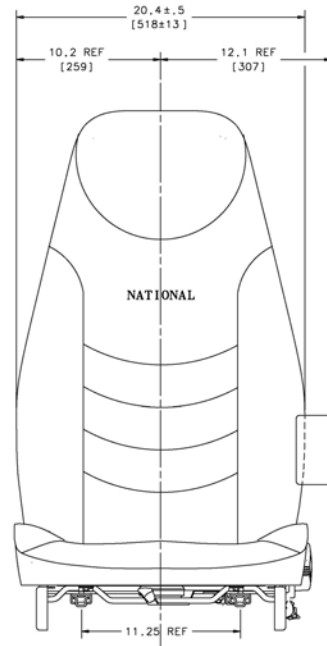
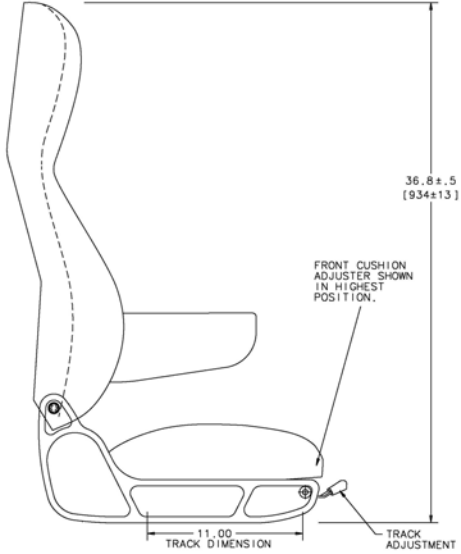

FRONT CUSHION ADJUSTER

FCA TYPE	FWD ADJ	HGT ADJ
2 POS	2.0	.7

A	REMOVED RCA (05-1137, 4-25-05, TMW)
	RELEASE 05-1077, 2-23-05, TMW
SYM	CHANGE (E.C.N. - DATE - BY)

TOLERANCES		SCALE		DATE		PART NO.		DESCRIPTION		ITEM	
FORM	DO NOT SCALE	SCALE	1/4	DATE	2/23/05	PART NO.	00452	DESCRIPTION	AFTERMARKET NATIONAL 2000 *PREMIUM* LO-PROFILE W/O CHUGGER	ITEM	A

Hackney BEV Chassis Components

Mitsubishi FUSO lighting switch pinouts

Part #MK420436

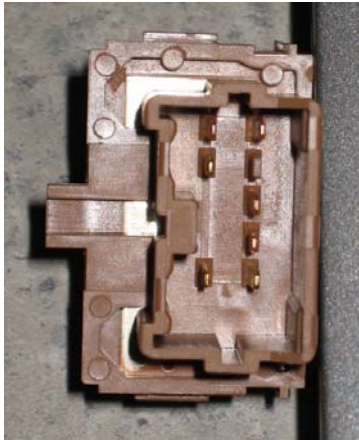

Instrument Panel
Cutout Dimensions

1.45" – 36.95mm

1.013" – 25.72mm

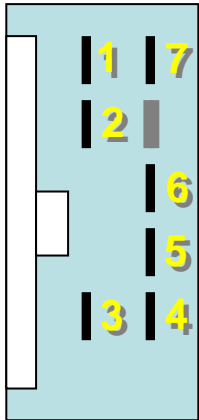

- 1: switched circuit + positive
- 2: dash lighting circuit + positive
- 3: switch indicator lamps circuit – negative
- 4: switch on position indicator lamp + positive
- 5: “off” position switch closed circuit
- 6: “on” position switch closed circuit
- 7: not used in this version of the switch assembly

Note: these numbers are arbitrary assignments and do not correlate to the #'s in the Mistu/Fuso FG documentation schematics

Hackney BEV Chassis Components

Rear Video Camera Wiring

- Black & Shield – tied together – tied to shield on video & audio RCA jacks
- Clear – video
- Red - +12VDC
- White - audio

Camera wiring harness

Bulgin Buccaneer Female

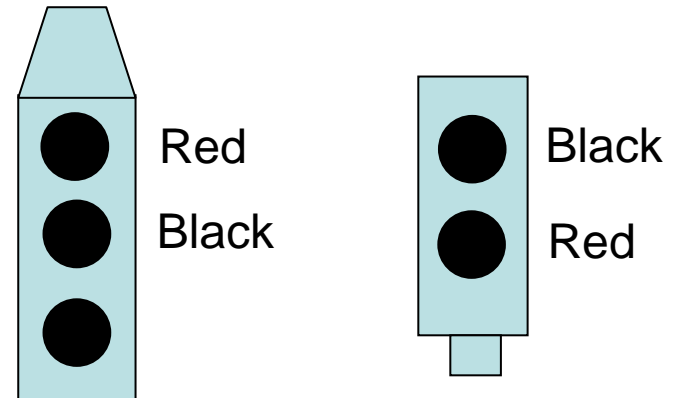
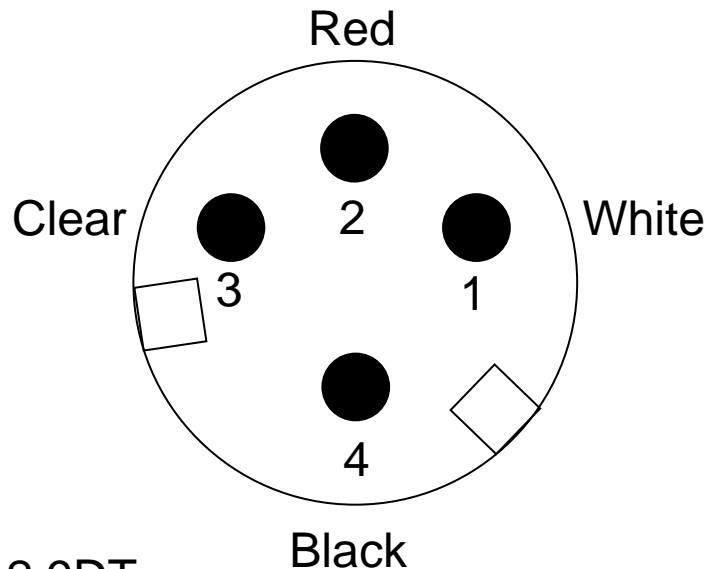

Hackney BEV Chassis Components

Remote Control Panel RJ45

Red – Surge Guard

Blue – Xantrex System Control

White – Solar Panel Controller

Green – Xantrex 240VAC battery charger

Hackney BEV Chassis Components

Alternator Field Disconnect Connector

Bulgin Buccaneer Female

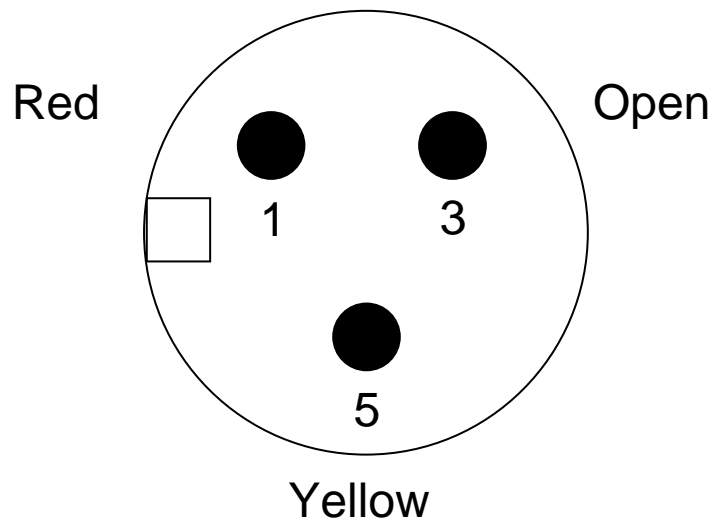

Hackney BEV Chassis Components

Water Hose Color Key

- Green – Shore pressure
- Orange – Raw Tank Return
- Blue – Fresh Tank Fill
- Yellow – Camper Pump Output
- Red – Raw Tank Output

Hackney BEV Chassis Components

Chassis Interconnect Panel

Pump Connector

Bulgin Buccaneer Female

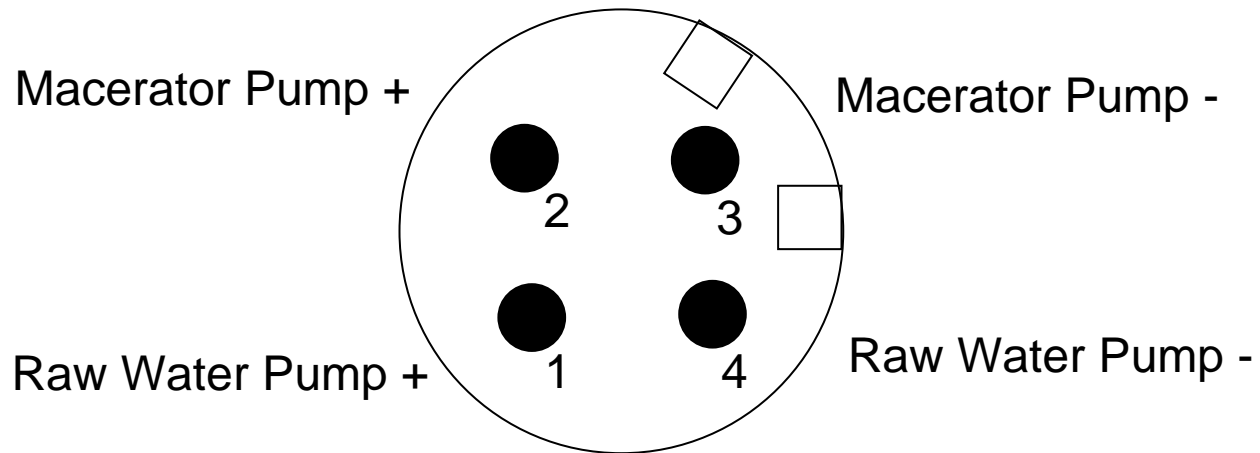

Hackney BEV Chassis Components

Chassis Interconnect Panel

Genset remote & LP Solenoid Connector

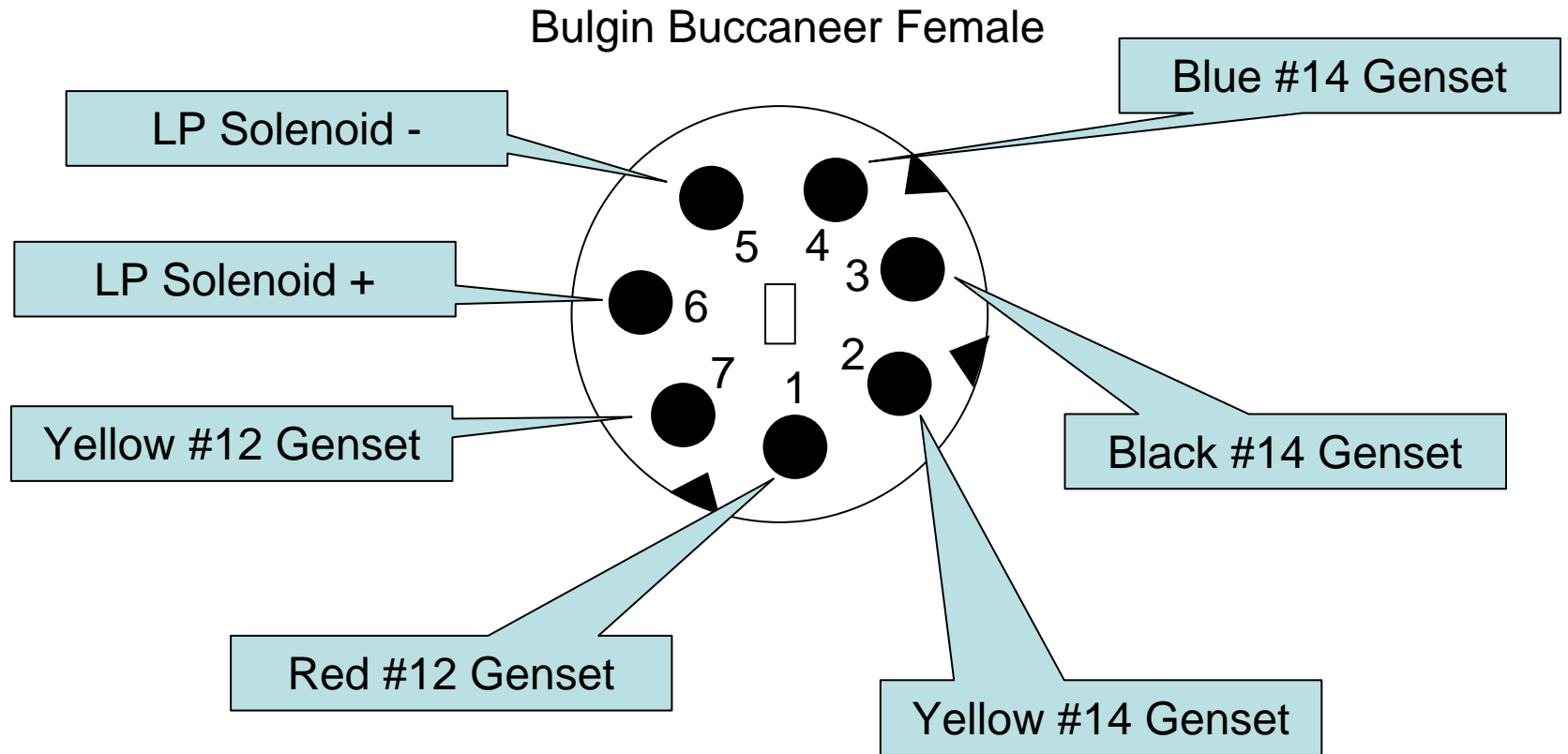

Hackney BEV Chassis Components

Chassis Interconnect Panel

House Bank & Start Bank APP HPA & HPB connectors

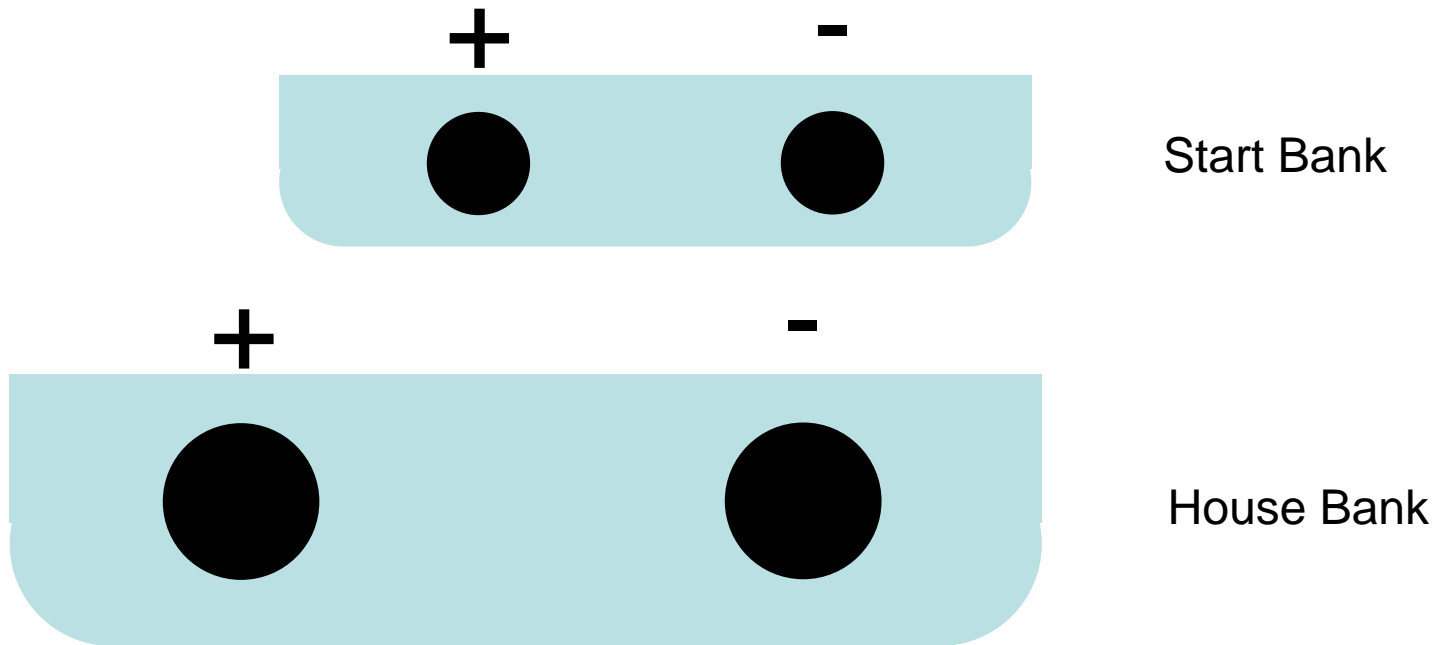

Hackney BEV Chassis Components

Chassis Interconnect Panel

LP fuel gauge connector

Yellow -

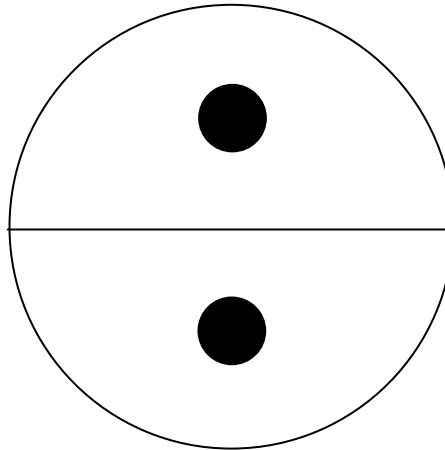

Red +

Hackney BEV Chassis Components

Chassis Interconnect Panel

Box lighting & Raw Water tank heater

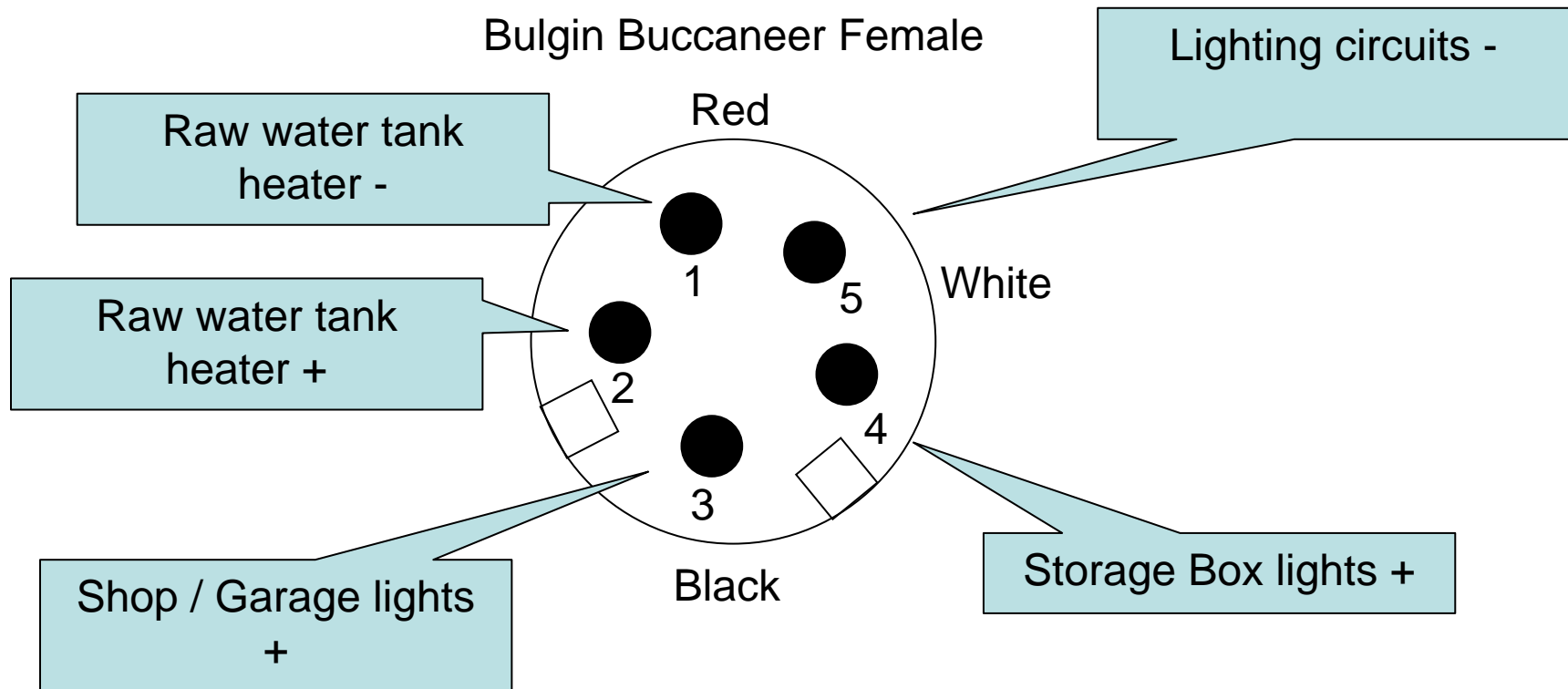

Hackney BEV Chassis Components

Chassis Interconnect Panel

120VAC Shop & Genset connectors

Hubbell Connectors

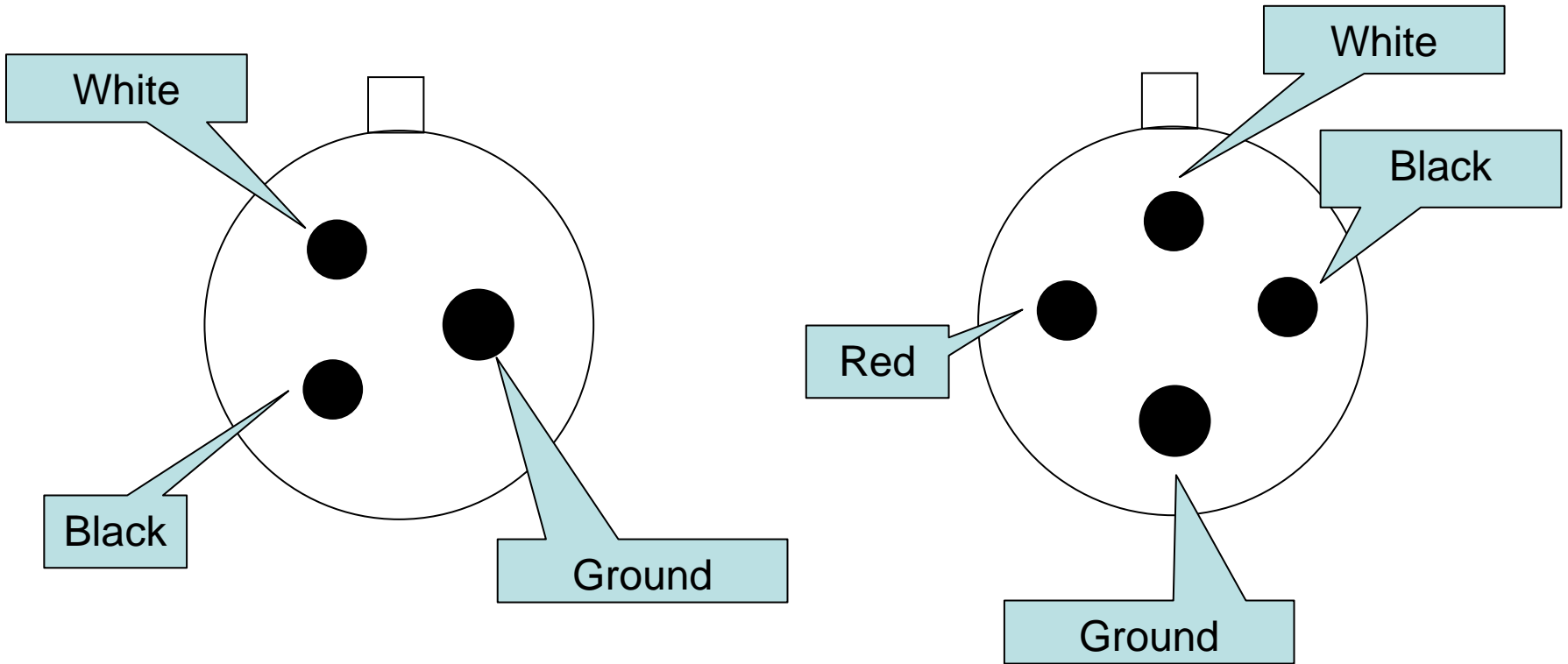

Hackney BEV Chassis Components

Camper Interconnect Panel

Solar & Start Bank voltage connector

Bulgin Buccaneer Female

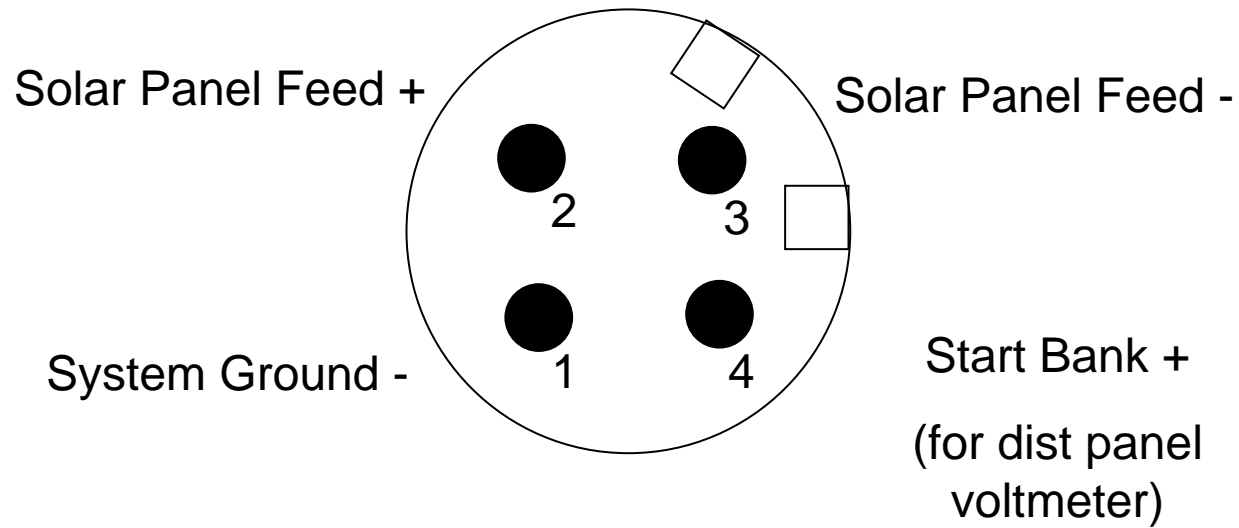

Key One

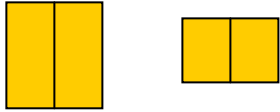

Lifeline AGM Batteries
(4) GPL-4DA

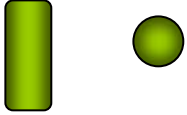

Compressed Air Tank



Diesel Fuel Tanks (2)
~75 gallons each

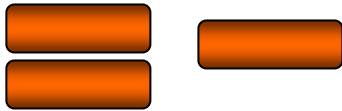

Sleeper Engineering
11x11x28SEUW propane
tanks, 16 USG @80%

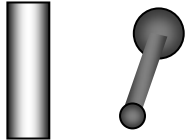

Relocated stock
Mitsu/Fuso muffler

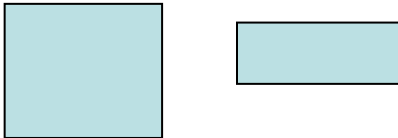

Raw water tank ~50
gallons

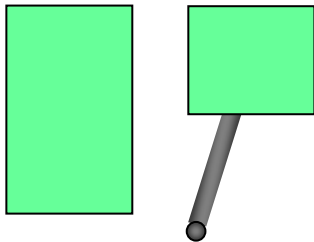

Onan 7500 Diesel
Genset



Garage w/Honda 150F
storage



Chassis mount storage
compartments

Key Two

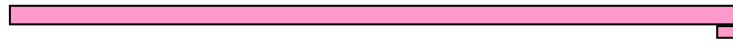
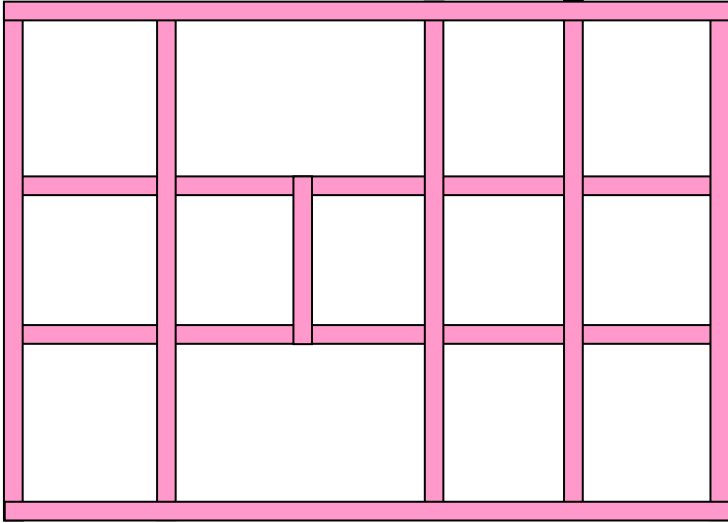

3 point pivot camper support frame

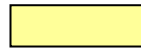
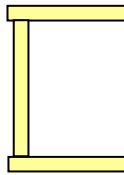

Mid frame extension

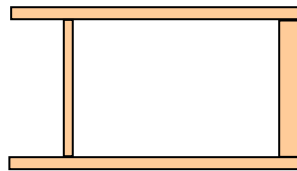

Rear frame extension

Key Three

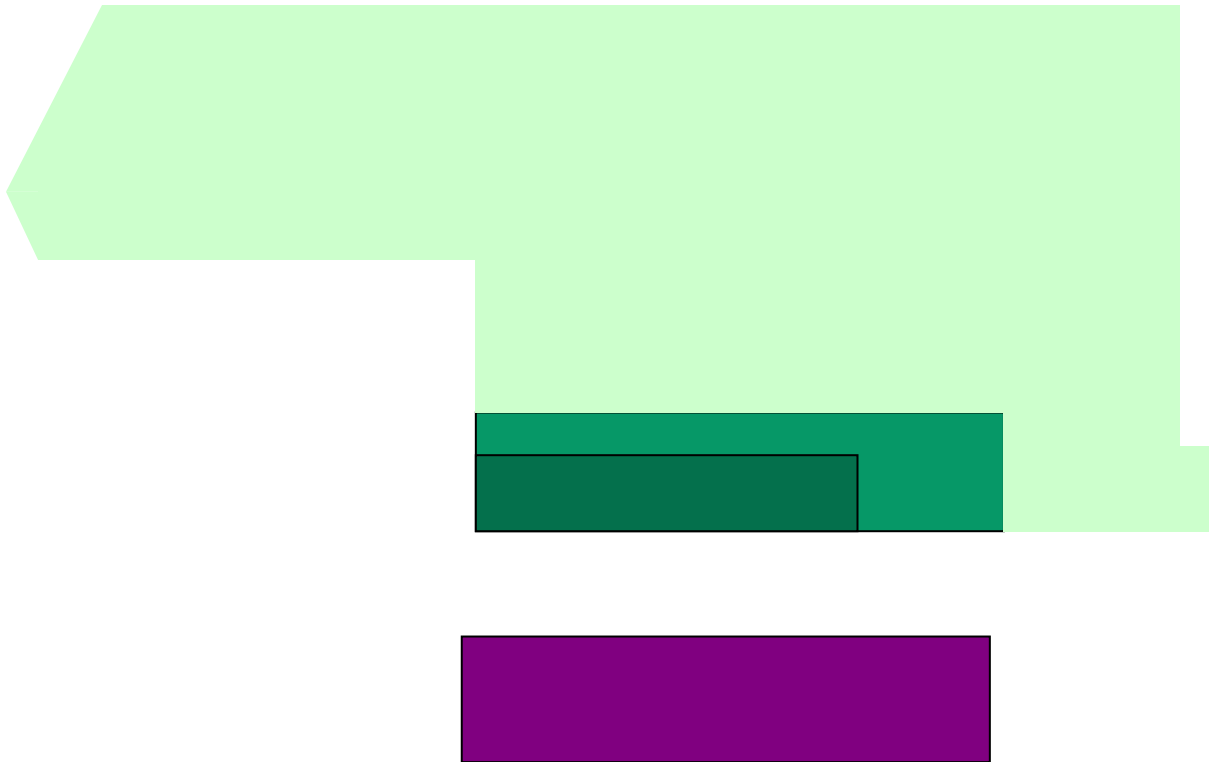

Bigfoot 30C10.11FR
Pickup Camper

3 point frame mount
storage compartments

Key Four



Front bull bars

Rear bull bars

Front Warn 16k winch

Rear Warn 16k winch

Key Five

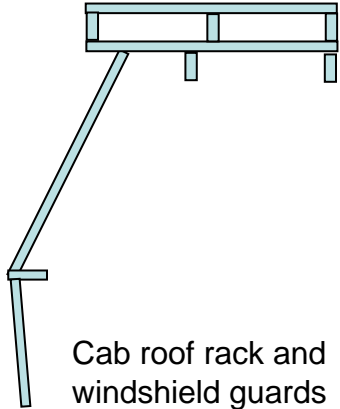
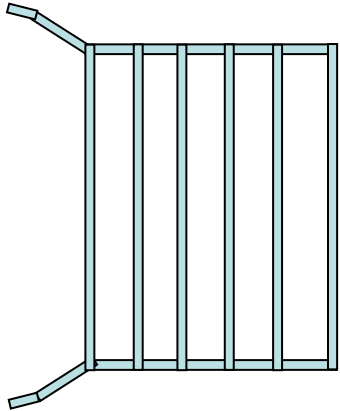

Chassis Rub Strip



Garage Rub Strip

Camper Rub Strip

Key Six

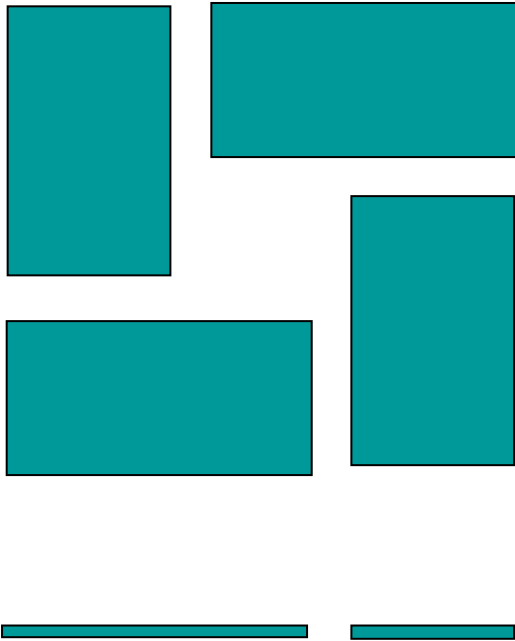

Solar Cells



Start Batteries

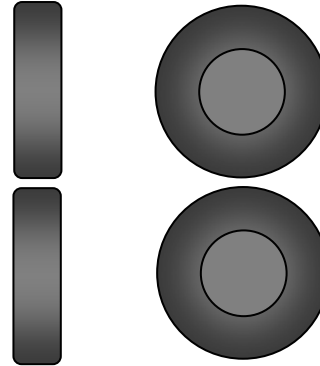

Spare tires & wheels

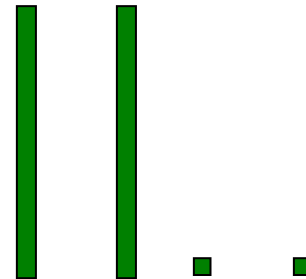

Kwikie Super Slide